

Windposts



Windposts



Check for updates



Product summary

ACS windposts are designed to span vertically between floors to provide lateral restraint to masonry panels. They often eliminate the need for additional steel or reinforced concrete columns, thus reducing time and costs involved in this method of construction. ACS produces a range of standard windposts that can be selected from a design table depending on the length, section and loading requirements.

C section windposts are installed within the cavity leaving the blockwork coursing and stretcher bonding undisturbed. They are commonly used in masonry panels that are subject to lower wind loadings.

L section windposts are installed into a vertical blockwork joint and protrude into the cavity area. They are designed for use where higher wind loadings may occur and, in some cases, where cavity widths restrict the use of C section windposts.

Spine section windposts can be built into a vertical blockwork joint and provide a cost effective solution usually for single skin blockwork walls.

On top of the range of windposts, which are designed to be fixed at both the top and bottom of the post back to the structure, ACS also design and fabricate a range of parapet posts. These are designed as a cantilevered beam and so often require larger base connection to resist the applied bending moments.

ACS can also fabricate and supply box section posts based upon structural engineer's designs. These are typically built into a blockwork wall, however they can also be concealed within the cavity in high load applications due to their greater sectional properties when compared to both C and L section posts.



UKCA / CE+UKNI marked

Windposts



Product highlights



Posts designed to Eurocodes 3 & 6

Ties designed to BS EN 845

Stainless or carbon steel

Specialist design team

Value engineered solutions

Standard or bespoke designs

Installation

All ACS windposts are supplied complete with site-specific layout and section details for the post, head and base fixings and ties to assist the installation team. The windposts are supplied with a rigid base connection and a separate top cleat designed with a slotted connection to allow for movement and tolerance.

Windposts

L Section Windposts

Windposts



Check for updates

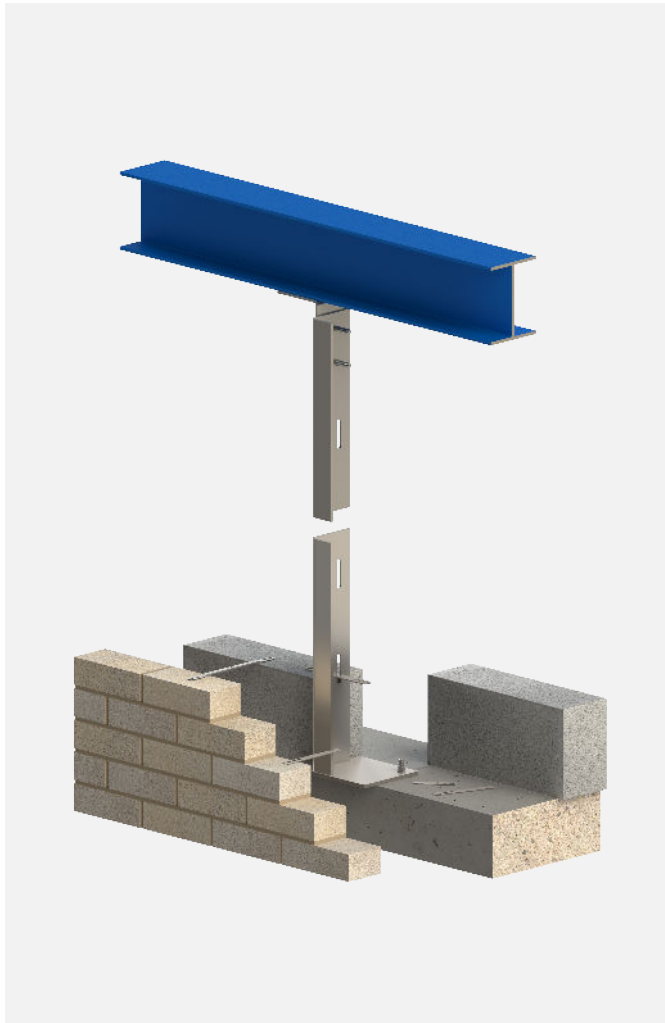

L section windposts

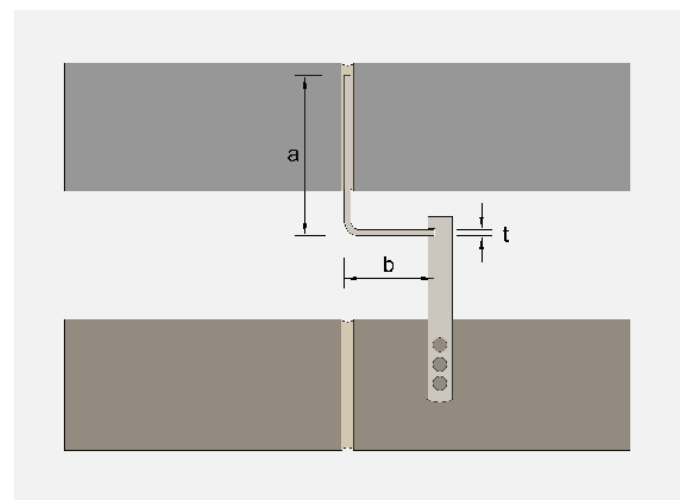
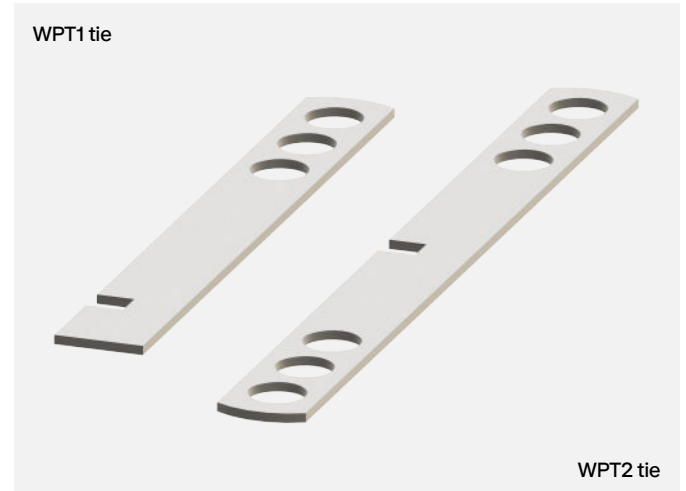

L section windposts are a cost effective structural system designed to suit each and every individual project.

The posts are built into the internal skin of blockwork and bolted to the structure via suitable fixings.

The use of WPT1 clip on ties to the external leaf and WPT2 clip in ties to the inner leaf transfer the loadings applied to the cladding back to the structure.

The following tables illustrate the typical sizes available, however almost any size can be designed/ manufactured.

Windposts



Check for updates

L section windposts

Windposts are designed as simply supported beams. Maximum deflection is height/360 and maximum stress is 191N/mm². Values based upon Stainless Steel Grade 304.

Section a x b x t	Ixx cm ⁴	Zxx cm ³	2.5m	3.0m	3.5m	4.0m	4.5m	5.0m	5.5m	6.0m
Maximum factored load for height of windpost (UDL) kN										
125 x 70 x 4	128.38	15.39	9.4	7.8	6.7	5.1	4.1	3.3	2.7	2.3
140 x 70 x 4	174.46	19.01	11.6	9.7	8.3	7.0	5.5	4.5	3.7	3.1
130 x 70 x 6	208.89	24.44	14.9	12.4	10.7	8.4	6.6	5.3	4.4	3.7
155 x 70 x 4	229.71	22.96	14.0	11.7	10.0	8.8	7.3	5.9	4.9	4.1
170 x 70 x 4	294.81	27.24	16.6	13.9	11.9	10.4	9.2	7.5	6.2	5.2
150 x 70 x 6	308.40	31.95	19.5	16.3	13.9	12.2	9.7	7.9	6.5	5.5
160 x 70 x 6	367.54	36.03	22.0	18.3	15.7	13.8	11.6	9.4	7.8	6.5
185 x 70 x 4	370.46	31.85	19.5	16.2	13.9	12.2	10.8	9.5	7.8	6.6
150 x 80 x 8	421.50	43.00	24.8	21.9	18.8	16.4	13.3	10.8	8.9	7.5
185 x 70 x 5	458.69	39.58	24.2	20.1	17.3	15.1	13.4	11.7	9.7	8.2
160 x 80 x 8	502.82	48.54	24.8	24.7	21.2	18.5	15.9	12.9	10.6	8.9
200 x 70 x 5	566.57	45.72	24.8	23.3	20.0	17.5	15.5	14.0	12.0	10.1

Windposts



Check for updates

L section parapet posts

Parapet and spandrel posts are designed as fixed base cantilevers. Maximum deflection is height/180 and maximum stress is 191N/mm². Values based upon Stainless Steel Grade 304.

Section a x b x t	Ixx cm ⁴	Zxx cm ³	0.8m	1.0m	1.2m	1.4m	1.6m	1.8m	2.0m
Maximum factored load for height of windpost (UDL) kN									
125 x 70 x 4	128.38	15.39	6.75	5.9	4.9	4.2	3.7	3.3	2.9
140 x 70 x 4	174.46	19.01	6.75	7.3	6.0	5.2	4.5	4.0	3.6
130 x 70 x 6	208.89	24.44	6.75	9.0	7.8	6.7	5.8	5.2	4.7
155 x 70 x 4	229.71	22.96	6.75	8.8	7.3	6.3	5.5	4.9	4.4
170 x 70 x 4	294.81	27.24	6.75	9.0	8.7	7.4	6.5	5.8	5.2
150 x 70 x 6	308.40	31.95	6.75	9.0	10.2	8.7	7.6	6.8	6.1
160 x 70 x 6	367.54	36.03	6.75	9.0	11.3	9.8	8.6	7.6	6.9
185 x 70 x 4	370.46	31.85	6.75	9.0	10.1	8.7	7.6	6.8	6.1
150 x 80 x 8	421.50	43.00	6.75	9.0	11.3	11.7	10.3	9.1	8.2
185 x 70 x 5	458.69	39.58	6.75	9.0	11.3	10.8	9.4	8.4	7.6
160 x 80 x 8	502.82	48.54	6.75	9.0	11.3	13.2	11.6	10.3	9.3
200 x 70 x 5	566.57	45.72	6.75	9.0	11.3	12.5	10.9	9.7	8.7

Windposts

C Section Windposts

Windposts



C section windposts

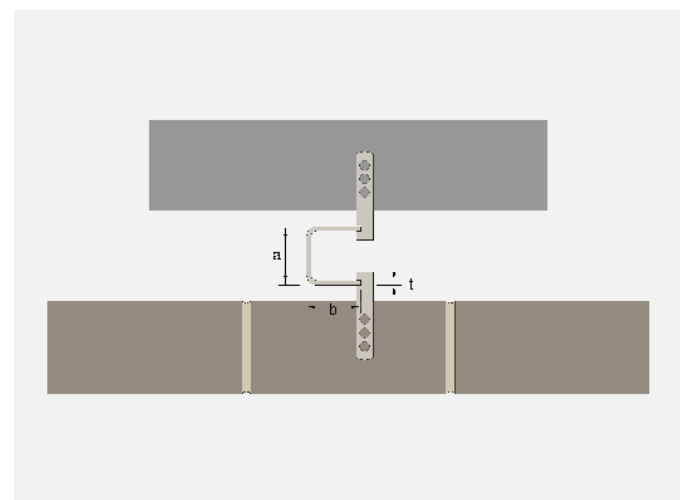

C section windposts are designed within the cavity and eliminate the need for cutting blockwork. The posts are bolted to the structure with suitable fixings. The use of WPT1 clip on ties to both the external and internal leaf transfer the loadings applied to the cladding back to the structure.

The following tables illustrate the typical sizes available; however, almost any size can be designed/ manufactured.

Windposts



Check for updates

C section windposts

Windposts are designed as simply supported beams. Maximum deflection is height/360 and maximum stress is 191N/mm². Values based upon Stainless Steel Grade 304.

Section a x b x t	Ixx cm ⁴	Zxx cm ³	2.5m	3.0m	3.5m	4.0m	4.5m	5.0m	5.5m	6.0m
Maximum factored load for height of windpost (UDL) kN										
55 x 60 x 4	32.05	11.66	3.3	2.3	1.7	1.3	1.0			
55 x 60 x 5	37.37	13.59	3.8	2.7	2.0	1.5	1.2	1.0		
65 x 60 x 4	47.18	14.52	4.8	3.4	2.5	1.9	1.5	1.2	1.0	
65 x 60 x 5	55.43	17.06	5.7	3.9	2.9	2.2	1.8	1.4	1.2	1.0
75 x 60 x 4	65.71	17.52	6.7	4.7	3.4	2.6	2.1	1.7	1.4	1.2
75 x 60 x 5	77.65	20.71	8.0	5.5	4.1	3.1	2.5	2.0	1.6	1.4
85 x 60 x 4	87.86	20.67	9.0	6.2	4.6	3.5	2.8	2.2	1.9	1.6
85 x 60 x 5	104.30	24.54	10.7	7.4	5.4	4.2	3.3	2.7	2.2	1.9
95 x 60 x 5	135.63	28.56	13.9	9.6	7.1	5.4	4.3	3.5	2.9	2.4
105 x 60 x 5	171.91	32.75	16.5	12.2	9.0	6.9	5.4	4.4	3.6	3.1
115 x 60 x 5	213.39	37.11	16.5	15.2	11.1	8.5	6.7	5.5	4.5	3.8
115 x 60 x 6	245.40	42.68	16.5	17.5	12.8	9.8	7.8	6.3	5.2	4.4

Windposts



Check for updates

C section parapet posts

Parapet and spandrel posts are designed as fixed base cantilevers. Maximum deflection is height/180 and maximum stress is 191N/mm². Values based upon Stainless Steel Grade 304.

Section a x b x t	I _{xx} cm ⁴	Z _{xx} cm ³	0.8m	1.0m	1.2m	1.4m	1.6m	1.8m	2.0m
Maximum factored load for height of windpost (UDL) kN									
55 x 60 x 4	32.05	11.66	4.5	4.3	3.0	2.2	1.7	1.3	1.1
55 x 60 x 5	37.37	13.59	4.5	5.0	3.5	2.5	1.9	1.5	1.2
65 x 60 x 4	47.18	14.52	4.5	5.5	4.4	3.2	2.5	1.9	1.6
65 x 60 x 5	55.43	17.06	4.5	6.0	5.1	3.8	2.9	2.3	1.8
75 x 60 x 4	65.71	17.52	4.5	6.0	5.6	4.5	3.4	2.7	2.2
75 x 60 x 5	77.65	20.71	4.5	6.0	6.6	5.3	4.0	3.2	2.6
85 x 60 x 4	87.86	20.67	4.5	6.0	6.6	5.6	4.6	3.6	2.9
85 x 60 x 5	104.30	24.54	4.5	6.0	7.5	6.7	5.4	4.3	3.5
95 x 60 x 5	135.63	28.56	4.5	6.0	7.5	7.8	6.8	5.6	4.5
105 x 60 x 5	171.91	32.75	4.5	6.0	7.5	8.9	7.8	6.9	5.7
115 x 60 x 5	213.39	37.11	4.5	6.0	7.5	9.0	8.9	7.9	7.1
115 x 60 x 6	245.40	42.68	4.5	6.0	7.5	9.0	10.2	9.1	8.1

Windposts

Spine Section Windposts

Windposts



Spine section windposts

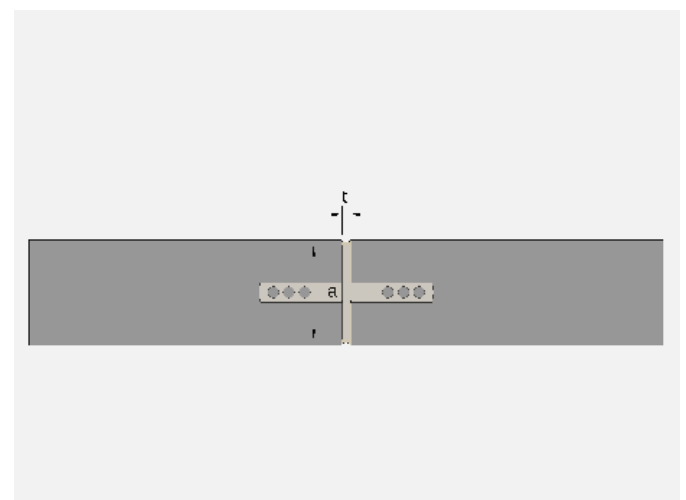

Spine section windposts are predominantly designed for use within an internal blockwork wall where relatively low wind loading occurs. They offer a cost effective solution and can be hidden within a vertical blockwork joint.

The posts are bolted to the structure with suitable fixings.

The use of WPT2 clip in ties transfers the loading applied to the blockwork back to the structure.

The following tables illustrate the typical sizes available; however, almost any size can be designed/ manufactured.

Windposts



Check for updates

Spine section windposts

Windposts are designed as simply supported beams. Maximum deflection is height/360 and maximum stress is 191N/mm². Values based upon Stainless Steel Grade 304.

Section	Ixx	Zxx	2.5m	3.0m	3.5m	4.0m	4.5m	5.0m	5.5m	6.0m
a x b x t	cm ⁴	cm ³	Maximum factored load for height of windpost (UDL) kN							
90 x 8	49	10.8	5.0	3.5	2.5	1.9	1.5	1.2	1.0	0.9
100 x 8	67	13.3	6.8	4.7	3.5	2.7	2.1	1.7	1.4	1.2
110 x 8	89	16.1	9.1	6.3	4.6	3.5	2.8	2.3	1.9	1.6
120 x 8	115	19.2	11.7	8.2	6.0	4.6	3.6	2.9	2.4	2.0

Windposts

Installation

Windposts



Check for updates

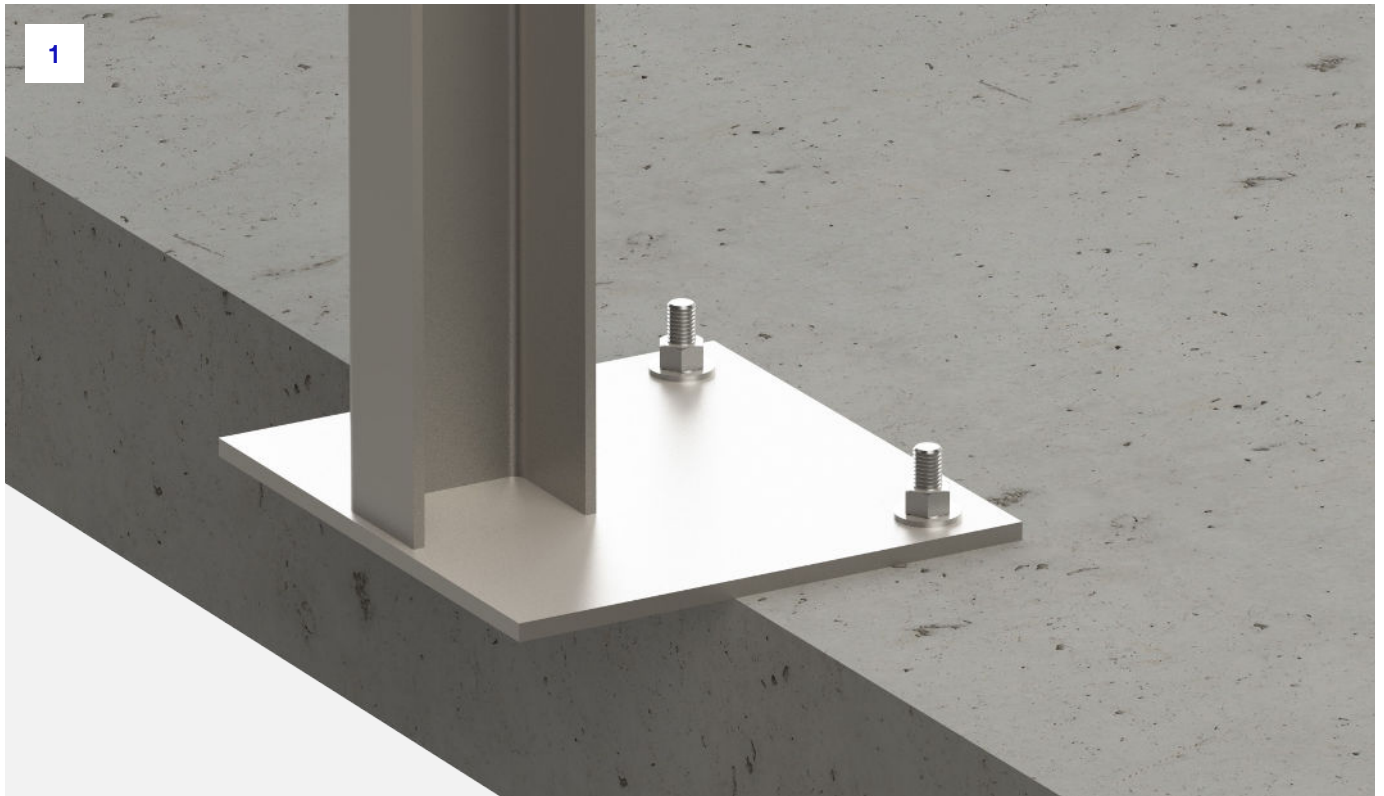

Base plates

1. Located at the base of the windpost is a welded baseplate. This is designed to fit around the corresponding structure and as such a bespoke solution will be provided for approval. A typical concrete slab edge detail can be found opposite.

Windposts



Check for updates



Top cleats

At the top of the windpost there are two holes for the installation of top cleats. Dependent on the structure available for fixing to, numerous cleat designs can be implemented. A number of these can be found below, however please contact ACS with any site specific requirements. All cleats include slotted connections to allow for movement and tolerance of the structure.

2. Underside of concrete

Fixing using M12 expansion anchors into the underside of a concrete structure.

Windposts



Check for updates



3. Steel beam

Fixings are to be placed through a beam flange. If access is available, fixings will be supplied as setscrews. If there is limited access, blind bolts can be supplied to aid with installation. Due to the dissimilar materials used, the stainless components should be isolated from the carbon steel elements.



4. Timber joist

When fixing to a joist, suitable timber noggins should be utilised to the project engineer's specification. Threaded bars will be supplied to be fixed fully through the timber with hex nuts and relevant washers placed on either side.



5. Timber wall plate

When fixing to the underside of a wall plate, threaded bars will be supplied to be fixed fully through the timber with hex nuts and relevant washers placed on either side. Timber should be specified by the project engineer to ensure it is capable of withstanding the applied loads.



Built on tradition. Driven by innovation.

Get in touch to learn more
about how ACS can help
you deliver your next project.

0113 391 8200
info@acsstainless.co.uk
acsstainless.co.uk

 ACS Stainless Steel Fixings Ltd
 ACSStainlessSteelFixings