

Intex™ 4-in-1 Masonry Support System

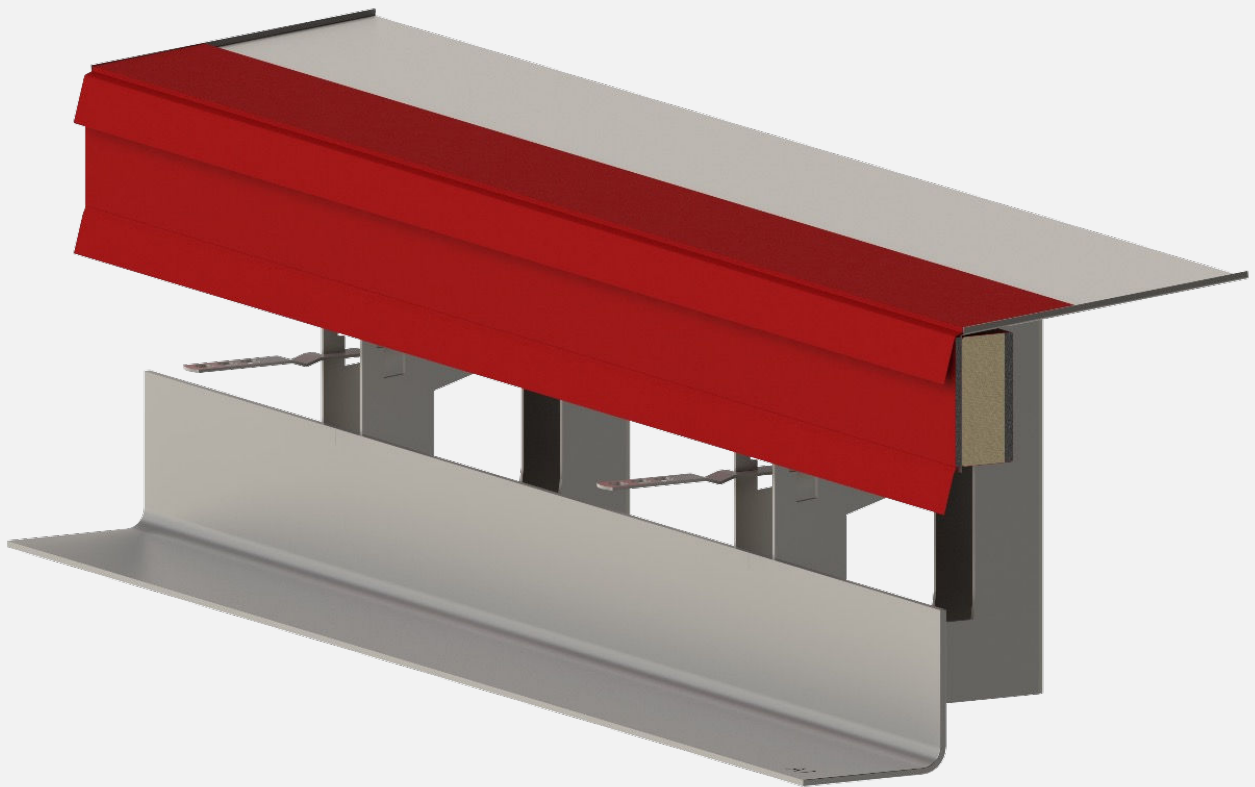

Designed in collaboration

Intex™ 4-in-1 Masonry Support System

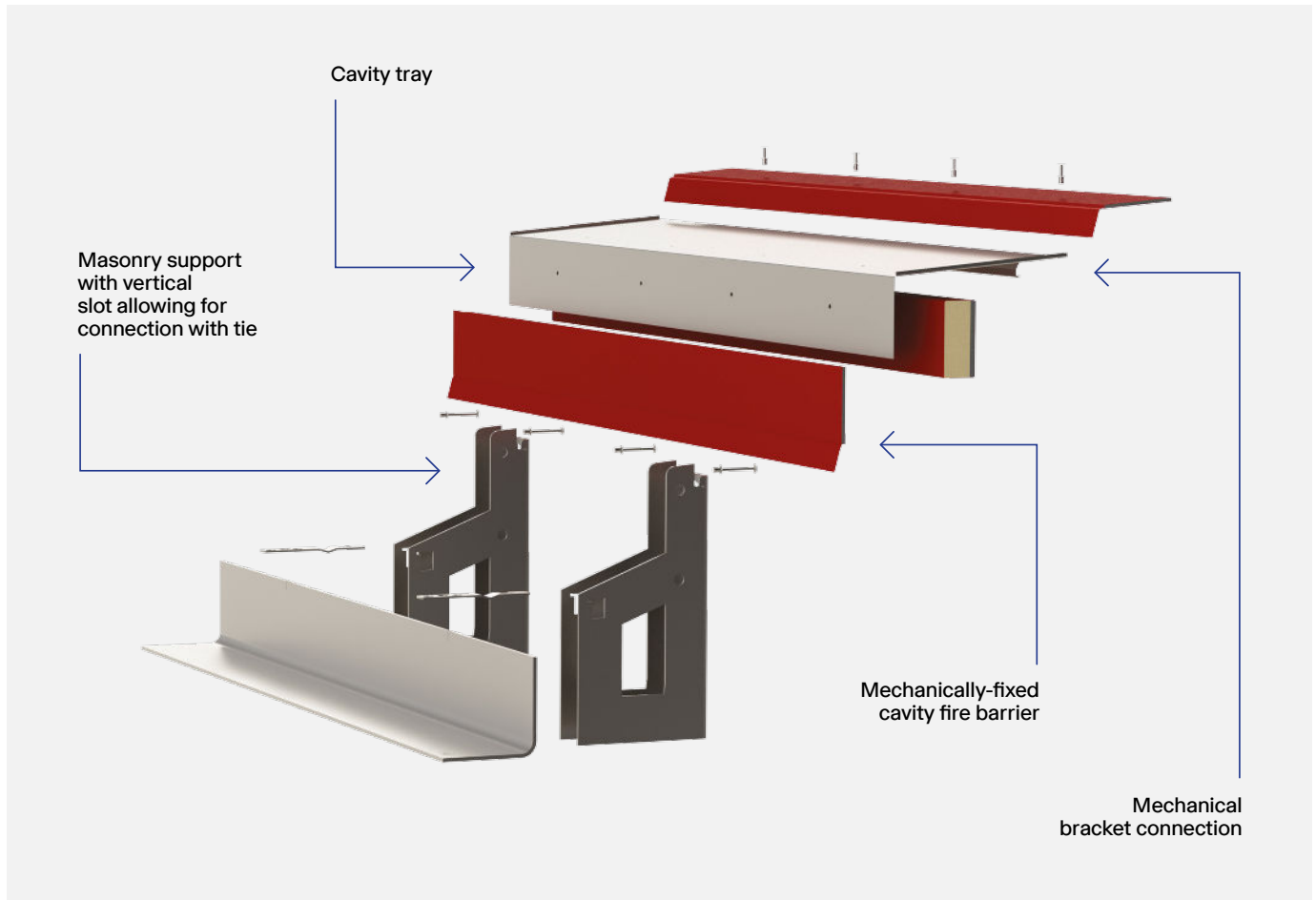

Product summary



60 Year
Design Life



Intex™ 4-in-1 Masonry Support is a combined masonry support system integrating four critical components into one easy-to-fit system. The product combines masonry support, cavity tray, wall ties, and an integrated cavity barrier into a single product, giving a large number of benefits to all involved parties. The product seeks to address a key issue in modern masonry façades, regarding cavity congestion around concrete floor slabs.

The product is designed to be used in brickwork façades, fixing back to a concrete primary structure.

Intex™ 4-in-1 Masonry Support System

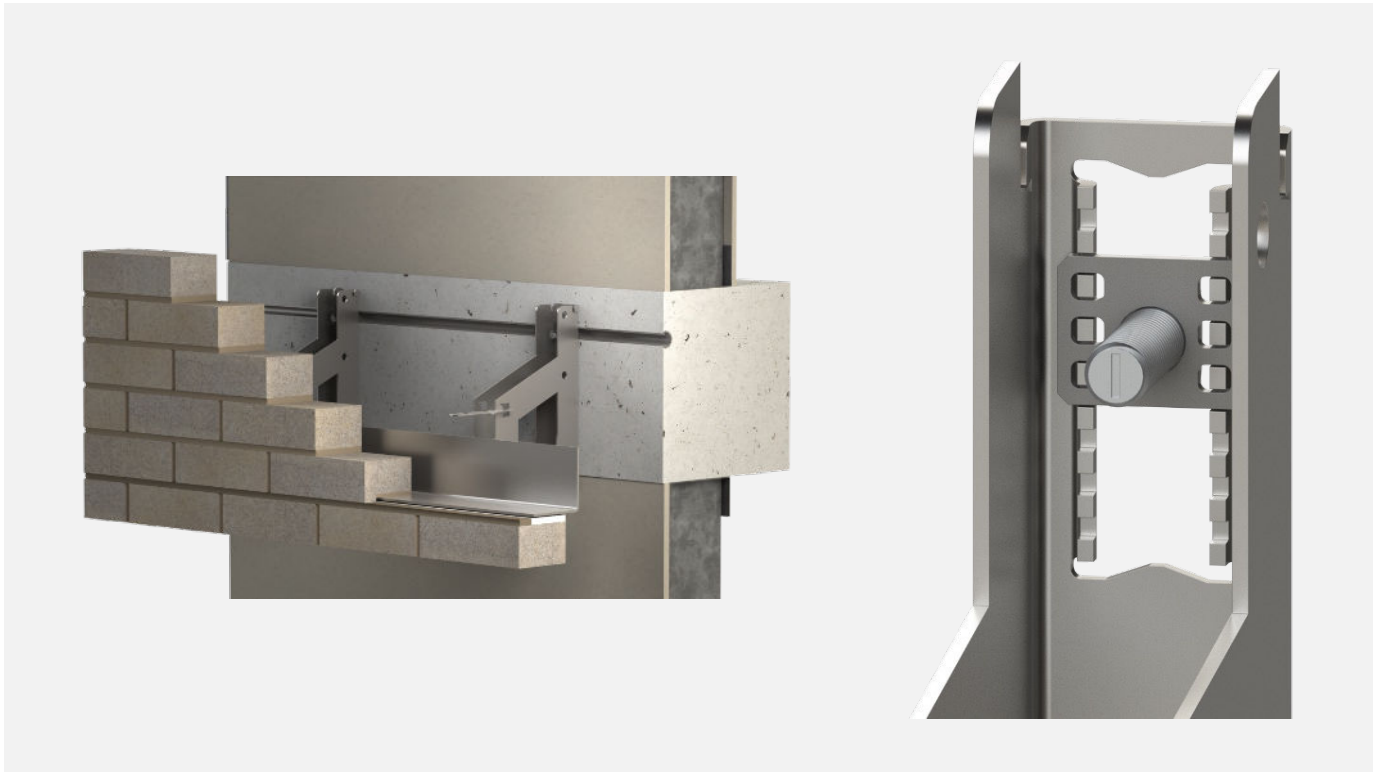

Masonry support

The masonry support element of Intex™ is designed in the same manner as traditional masonry support, with improvements made to ensure it is fully fit for purpose and assist with installation ease. Brickwork will be built upon the angle and the vertical load transferred back to the primary structure via brackets and relevant fixings.

A redesigned top bracket section allows for improved access when installing fixings. The system utilises the Alpha II adjustment method, giving the system $\pm 25\text{mm}$ vertical tolerance during installation. As each piece of support is designed for each individual scenario, the system itself is designed using a bespoke calculation for each iteration, following the guidance of relevant structural standards.

Intex™ 4-in-1 Masonry Support System



Check for updates

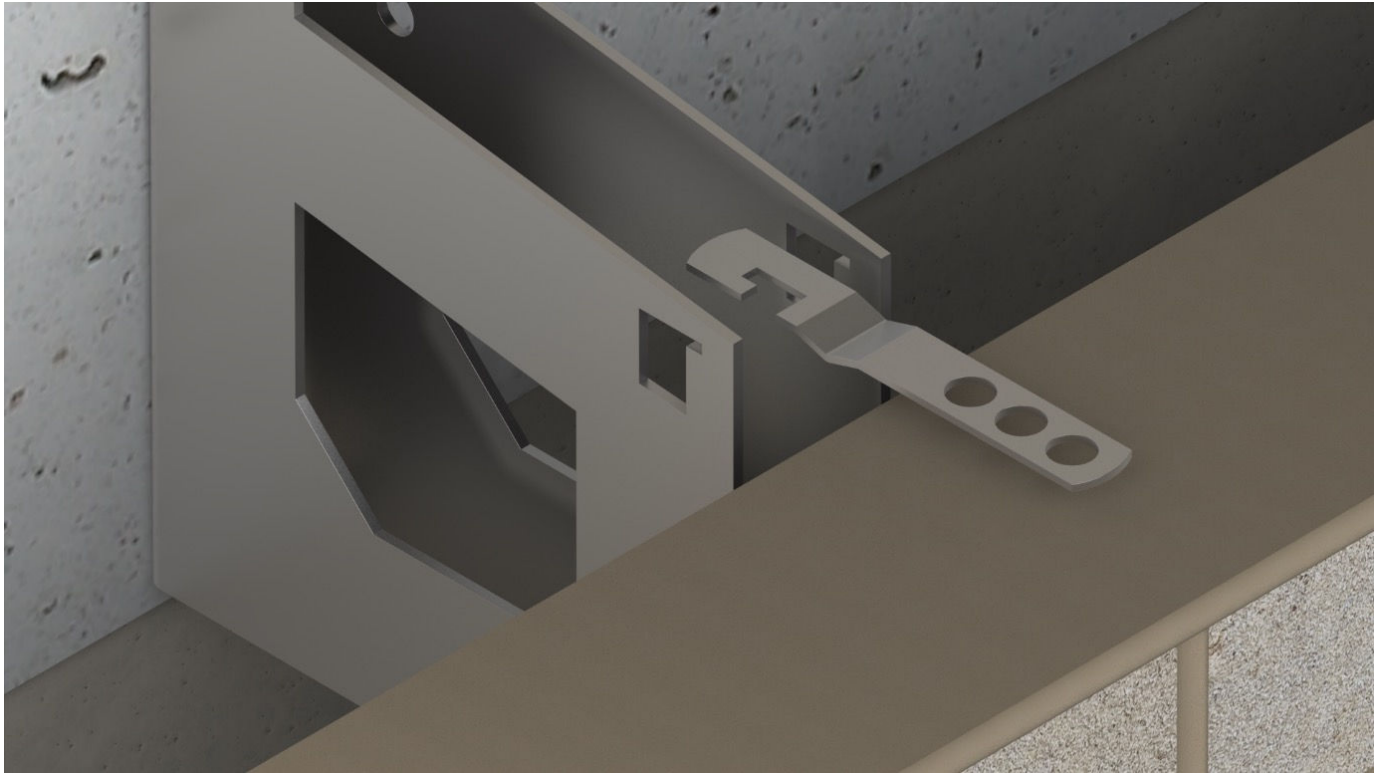

Wall tie

The system includes integrated wall tie slots which allow specially designed wall ties to be simply clipped into the bracket, before being embedded into the brickwork mortar joint. The slot includes vertical adjustment to allow both standard and pistol bricks to be utilised upon the masonry support angle.

BS EN 846-5 embedment end test

Tensile	2520N
Compressive	2430N

BS EN 846-6 bracket end test

Tensile	3340N
Compressive	1960N

Intex[™] 4-in-1 Masonry Support System

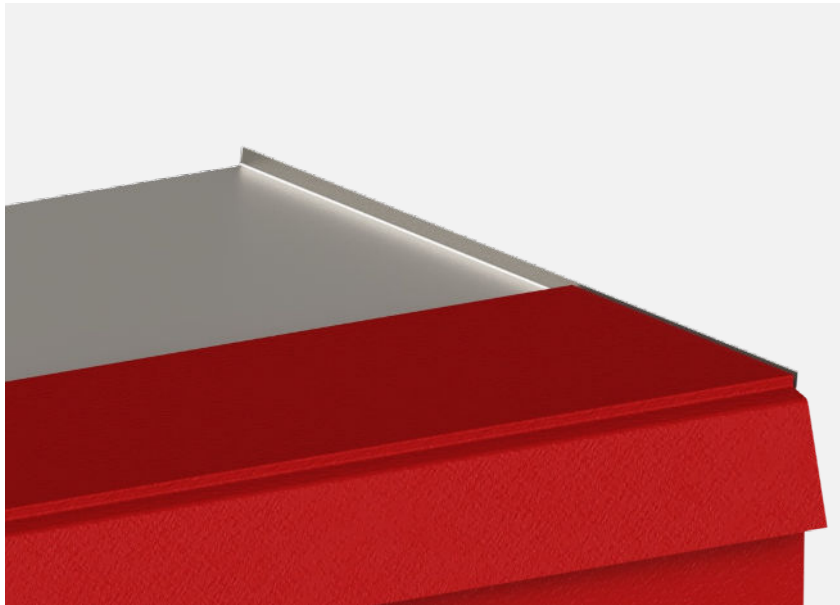

Cavity tray

The principles of the product follow the guidance from the ACS G-Tray[™] non-combustible cavity tray offering, and have been independently assessed as part of the Kiwa system certification. This can be split into two independent areas. Firstly, the masonry support angle doubles in purpose as the bottom tray of the cavity tray. To keep to these same principles, the angle has a minimum height of 100mm to ensure the system continues to function, even if mortar spots fall upon the angle during construction. Secondly, the top tray element is attached to the bracket and utilises a minimum overlap of 80mm between components. Each individual tray has upstand lips at its extremities to ensure there is zero risk of moisture penetration.



Between each masonry support angle is located a circa 10mm gap to allow for building tolerances. To counter this from a moisture perspective, a separate Intex[™] jointing piece is used to bridge the gap. This is attached in the same manner as the ACS cavity tray products, with both a double-sided butyl tape between the angle and jointing piece, as well as a single-sided butyl tape over the top of the joint. This has been independently assessed as part of the Kiwa third-party certification.

Intex™ 4-in-1 Masonry Support System

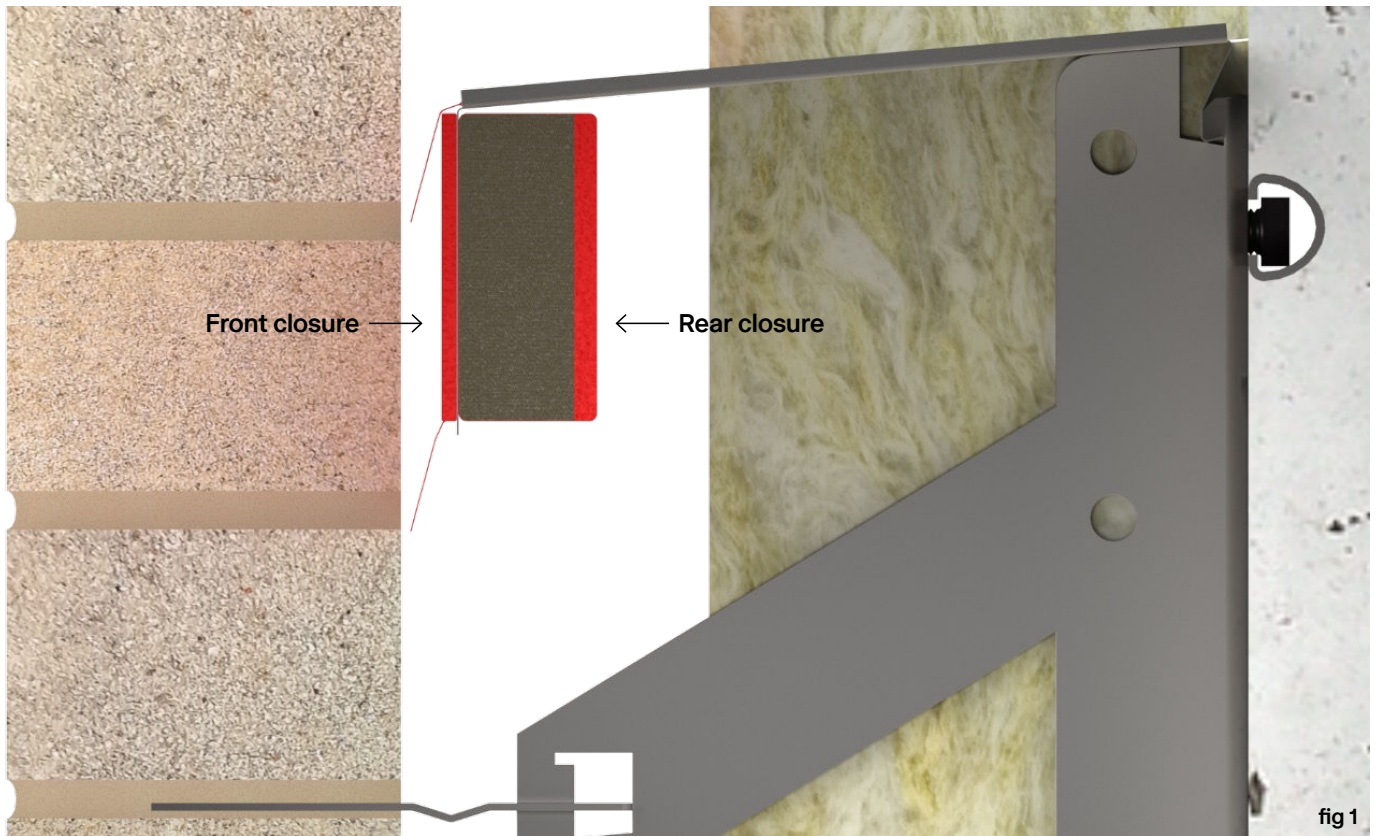

Cavity fire barrier

Tested at Warrington Fire, and subsequently assessed by UL Solutions, the integral open-state barrier has achieved test results in a number of scenarios, allowing for building tolerances in both the internal primary structure, as well as the external brickwork. The system was tested as a full assembly, with a maximum cavity size of 350mm. The testing can be split into two areas, the front closure and the rear closure which can be seen clearly in fig 1.

Intex™ 4-in-1 Masonry Support System



Intumescent

The Intex™ 4-in-1 Masonry Support system utilises an open state design for the cavity element. ACS have collaborated with Tenmat utilising their knowledge from 100 years' worth of working with advanced composite materials for safety-critical applications.

What makes the Tenmat product different?

In the case of the Intex™ intumescent, the main "carrier" material of the expandable graphite is in the form of fire resistance rock mineral fibres. They are combined together and built up in layers to create the finished material. This layering allows for unidirectional expansion which does not require containment and is therefore not at risk of being lost in a masonry cavity. Whereas alternative polymer based/rubber based intumescent often have less controlled 3D expansion which often needs containment.

It is the use of the rock mineral fibres combined with other inorganic, inert high temperature binders and a particularly low percentage of organic binder which not only provides excellent fire performance, but also results in a material that is much more resistant to diverse environmental conditions and does not exhibit any significant loss of performance due to ageing over time.

Barrier wings

To accompany the intumescent strips which activate upon the increase in temperature in the case of a fire, the system also includes innovative wings integrated into the strips that work in combination with the intumescent expansion to provide a quick and effective fire seal. This resulted in an innovation that allows for drainage in normal conditions and the immediate limitation of heat and fire spread in fire conditions.



Intex™ 4-in-1 Masonry Support System



Weep vents

Product-specific weep vents are available with the Intex™ system. The weep vents are manufactured from stainless steel, giving a number of benefits. Firstly, stainless steel is A1 non-combustible and is suitable for use in the external wall build-up. Secondly, as the product is to be used on a stainless steel angle and in the presence of moisture, there is no risk of bimetallic corrosion which can occur with dissimilar materials.

Standards and certification

Fire testing

The full Intex™ 4-in-1 Masonry Support system assembly has been subjected to a number of fire tests through Warrington Fire in order to attain results for both integrity and insulation ratings of the barrier. The testing was completed on differing gap sizes from both the front and rear intumescent strips.

Third party fire test assesment (UL)

UL Solutions conducted a third-party assessment upon the test reports conducted to the general principles of ASFP TGD19: 2017 and EN 1366-4: 2021 standards.

This third-party independent assessment showed that the product achieved the following ratings:

≤15mm front closure and ≤34.5mm rear closure
120 minutes integrity, 90 minutes insulation.

≤20mm front closure and ≤39.5mm rear closure
60 minutes integrity, 30 minutes insulation.

≤20mm front closure and 0mm rear closure
90 minutes integrity, 60 minutes insulation.

The independent assessment gives a number of stipulations as to where these values are valid.

- The minimum bracket height is 180mm.
- Cavity sizes should be between 150mm and 350mm.
- The thermal insulation used with the product must be of a mineral wool composition with a minimum density of 60kg/m³.
- The product can be used with either SFS or brick/block internal structures.
- Where steel framed partitions are used the face adjacent to the cavity shall be lined with minimum 12.5mm thick sheathing board with a density of minimum 600kg/m³ and an A class reaction to fire rating.
- External wall brick to be a minimum thickness of 100mm and a minimum density of 660kg/m³.

Intex™ 4-in-1 Masonry Support System



Kiwa third-party assessment

The Intex™ 4-in-1 Masonry Support system has independent certification, achieving a Kiwa BDA Agrément Certificate. The Agrément contains a number of criteria as to which the system has been assessed. Full details should be taken from the certificate BAW-23-307-S-A-UK, although the key points are summarised opposite.

– Moisture control

The system, including the sealed joints and associated ancillaries, acts as a barrier to the passage of water in the form of precipitation. Water would typically be discharged from the cavity through weep vents.

– Strength

It is important that the supporting wall has sufficient strength to withstand all wind, dead, and imposed loads. The strength of the supporting wall should be verified by a specifier to ensure the system offers sufficient resistance.

– Fire performance

The main system components are classified as European Classification A1 in accordance with BS EN 13501-1.

The system, when incorporating various wall components, have been tested to BS EN 1366-4 and ASFP TGD19 as well as the subsequent UL Solutions assessment.

– Durability

The system shall have a service life durability equivalent to that of the building into which it is incorporated. The expected lifespan of the building should be at least 60 years.

The aging performance of the cavity barrier element has been approved for 60 years for normal temperatures in the range -5°C to +30°C or intermittent extremes in the range -20°C to +50°C.



Built on tradition. Driven by innovation.

Get in touch to learn more
about how Intex™ can help
you deliver your next project.

0113 391 8200
info@acsstainless.co.uk
acsstainless.co.uk

 ACS Stainless Steel Fixings Ltd
 ACSStainlessSteelFixings