

# Intex<sup>™</sup> 4-in-1 Masonry Support System

---

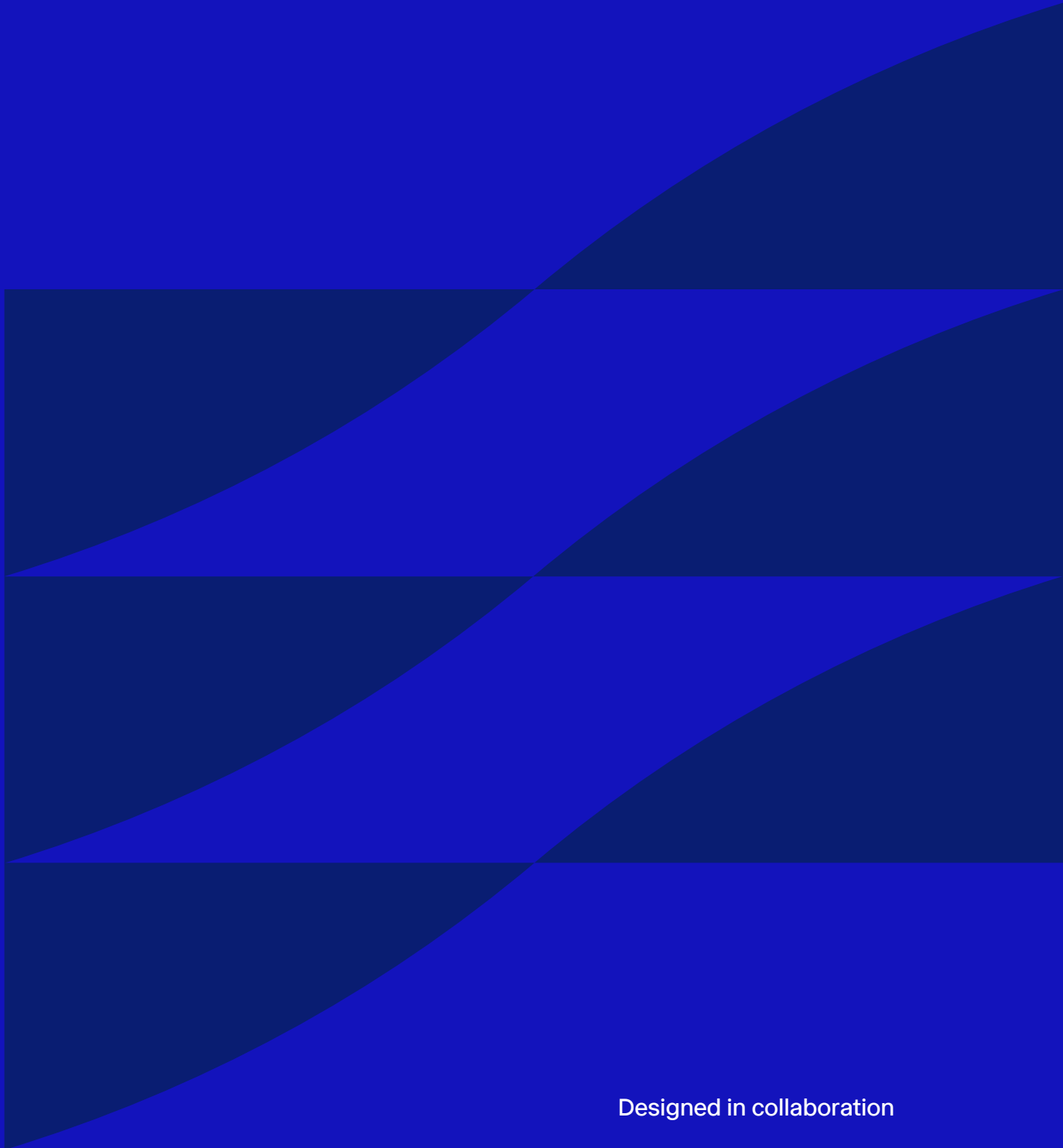

Designed in collaboration

# Intex™ 4-in-1 Masonry Support System

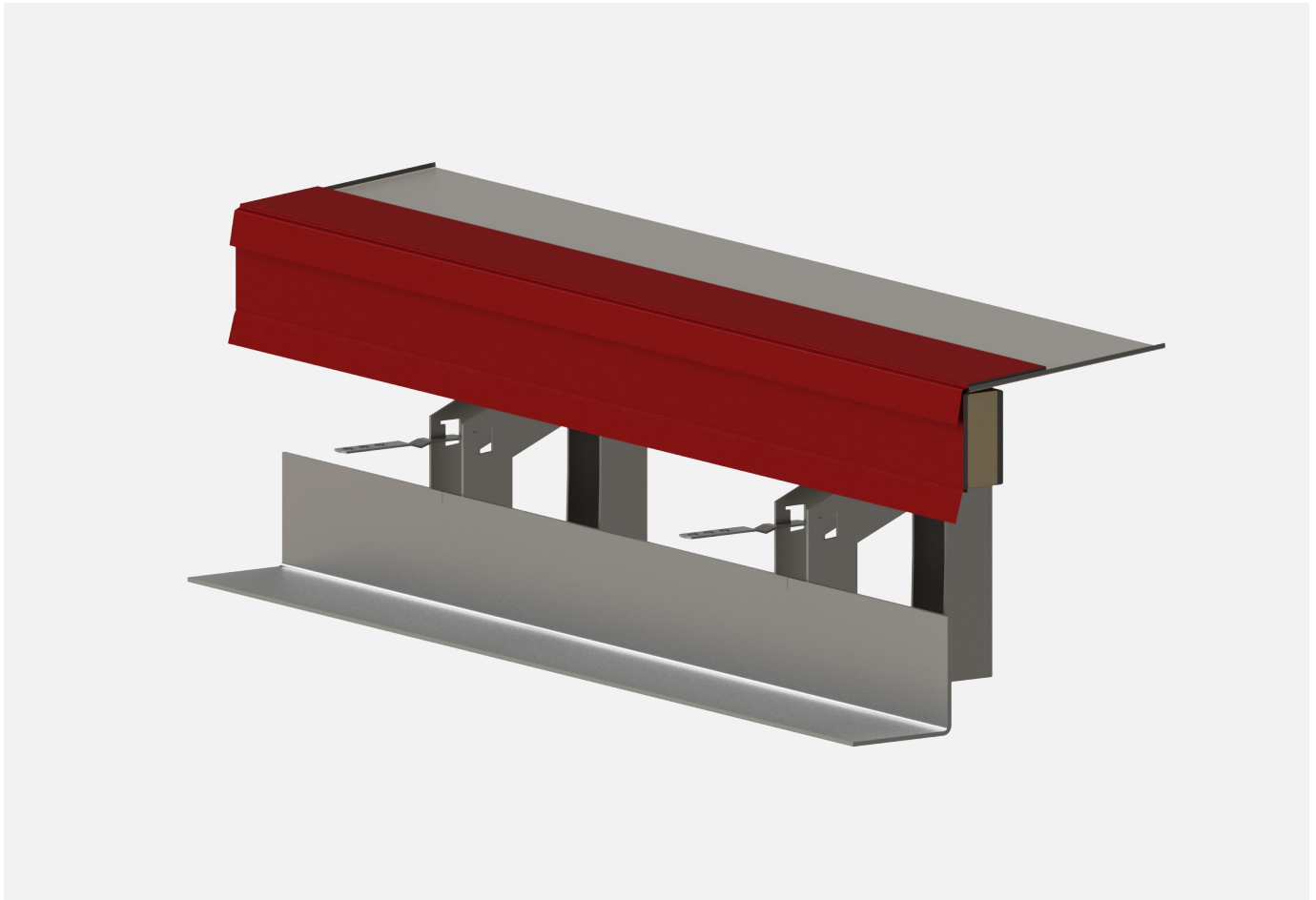

## Intex™ Installation

The following installation guide demonstrates the approved installation process for the Intex™ 4-in-1 Masonry Support system.

The correct use and installation of the Intex™ 4-in-1 Masonry Support system is critical for its function, durability, and long-term performance and so due care and attention should be taken. If there is any uncertainty during the installation process, work must stop and advice be sought on how to continue correctly. This guide contains general installation instructions for the system. For any bespoke components, additional guidance should be attained prior to installation.

Project-specific drawings will be supplied showing specific component references as well as section details containing information such as fixing location within the substrate edge. These drawings should be followed alongside this installation guide to ensure a compliant installation for the product.

While the skill set required for the installation of a typical product would be covered by those of a general (construction industry) fitter, ACS recommend the Association of Brickwork Contractors or similar short courses to understand the principles of the general components making up the system such as masonry support and cavity tray.

# Intex™ 4-in-1 Masonry Support System

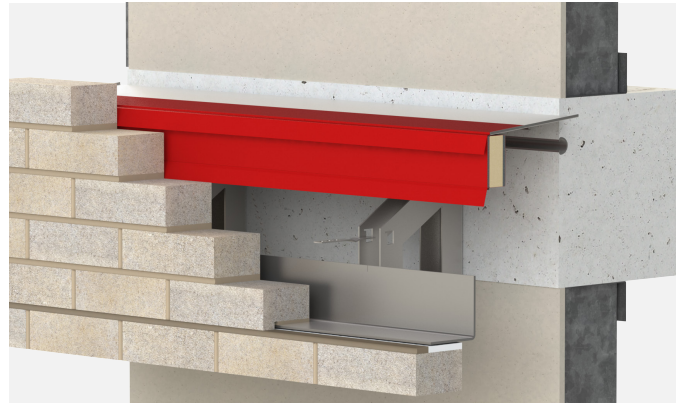
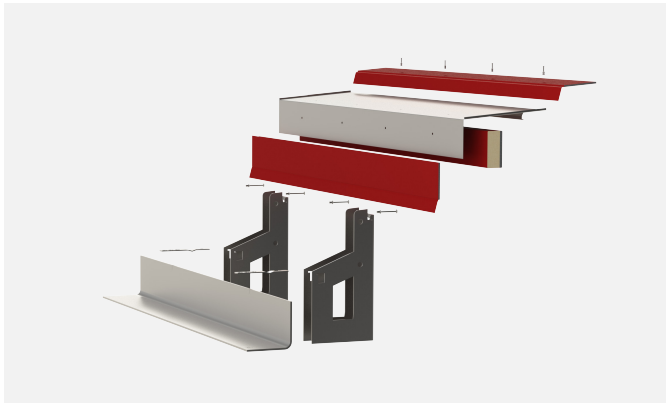

## Tools / Fitting

The tools required for installing Intex™ would commonly be found in a general construction worker's toolkit. As a minimum the following tools will be required; however, further tools may be required for specific details:

- |   |   |
|---|---|
| <p><b>1</b> PPE as required</p> <hr/> <p><b>2</b> Drill and drill bits to suit substrate type</p> <hr/> <p><b>3</b> Tape roller</p> <hr/> <p><b>4</b> Knife</p> <hr/> <p><b>5</b> Torque wrench and sockets</p> | <p><b>6</b> String line/laser level</p> <hr/> <p><b>7</b> Spirit level</p> <hr/> <p><b>8</b> Marker pen</p> <hr/> <p><b>9</b> Saw</p> |
|---|---|

# Intex™ 4-in-1 Masonry Support System



**1.** Refer to the relevant ACS approval drawing and locate the required reference for the first piece to be installed. Find this piece within the delivered Intex™ 4-in-1 Masonry Support and locate it in the relevant area of the building. Where required, the angle should be located above the horizontal movement joint following levels dictated by the design team. There should always be a gap left to allow for expansion of the masonry panel below. Site-specific drawings will give the required level for the angle to be set at.

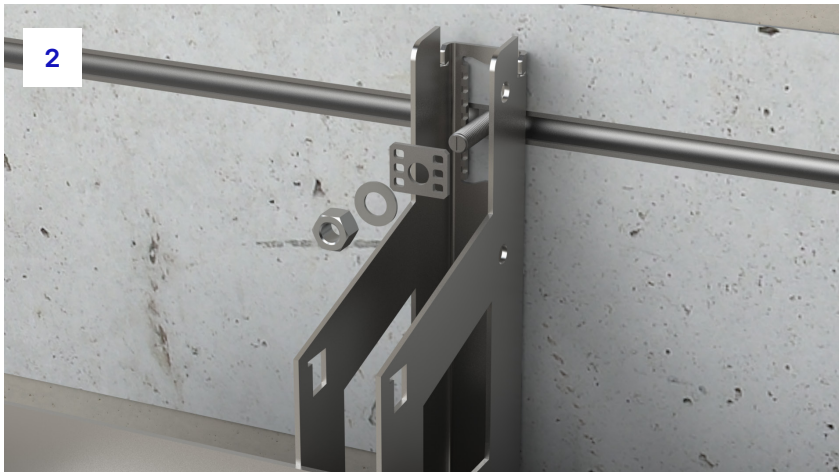

**2.** A fixing should be inserted through the bracket into the structure. For reference, ACS 31-21 cast in channel has been shown; however, please follow fixing specific installation instructions. Upon this fixing should be located an alpha adjustment washer which will allow for vertical tolerance, as well as a form B washer and hex head nut.

# Intex™ 4-in-1 Masonry Support System

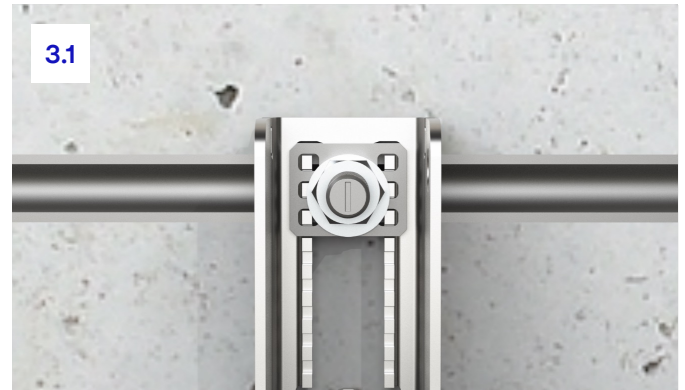

**3.** The ACS bracket contains the patented Alpha II adjustment methodology which can be used for required adjustment, offering  $\pm 25\text{mm}$  vertical tolerance. The washer can also be spun round  $180^\circ$  for fine adjustment between teeth. Please ensure that all minimum edge distances and fixing embedment depths are adhered to. For fixing specific information, please see relevant project approval drawings and fixing information.

**4.** Once the fixing is in the correct position both vertically and horizontally, the fixing should be tightened to the relevant torque setting which can be found on the ACS drawings.

# Intex™ 4-in-1 Masonry Support System



5. Continue to install further pieces of Intex™ brackets and angle, allowing for around a 10mm gap between units. Each angle should be levelled to the value shown upon the ACS drawings. A string line is commonly used to assist with installation. ACS drawings will show unit references which must be used to ensure the correct pieces are installed.



6. Once the Intex™ brackets and angles have been installed, it is necessary to create a continual barrier against moisture ingress. This is completed by using Intex™ jointing pieces and relevant sealing tapes.

# Intex™ 4-in-1 Masonry Support System



**7.** Utilise a strip of double-sided ACS Butyl tape on the end of each angle. This tape should be located at the end of the angle and should cover the full height and depth of the section to ensure full coverage against water. The tape has a top covering release layer that should be kept in place at this stage. Ensure that the tape is fully adhered to the angle. Once in place, the release tape can be removed.



**8.** Over the top of the joint utilise an Intex™ jointing piece to bridge the gap. This should overlap each angle by a minimum of 50mm. The piece allows for adjustment either way to allow for site tolerance.

# Intex™ 4-in-1 Masonry Support System



**9.** The Intex™ jointing piece should be pushed down into the tape to ensure good adhesion and to prevent water from being able to pass through.



**10.** On top of each side of the jointing piece, a strip of single-sided ACS Butyl tape should be utilised. This should sit half onto the jointing piece and half onto the angle below.



# Intex™ 4-in-1 Masonry Support System



**11.** The tape should be pushed into the joint to ensure good adhesion and to stop the passage of any moisture.



**12.** Once complete and the tape is sufficiently adhered, this gives a full barrier against moisture ingress.

# Intex™ 4-in-1 Masonry Support System

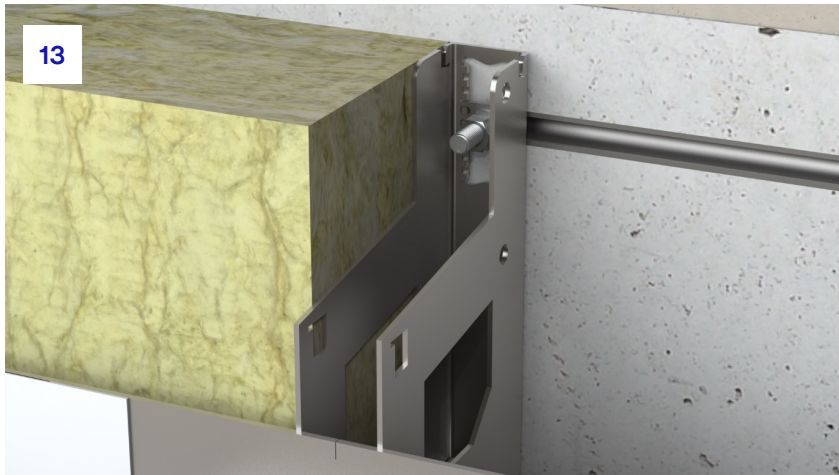

**13.** Thermal insulation should be installed tight up to the edge of each bracket and secured back to the structure following the manufacturer's instructions. Maximum gaps to the Intex™ barrier should be adhered to.

For more information, please see section details on project specific drawings.

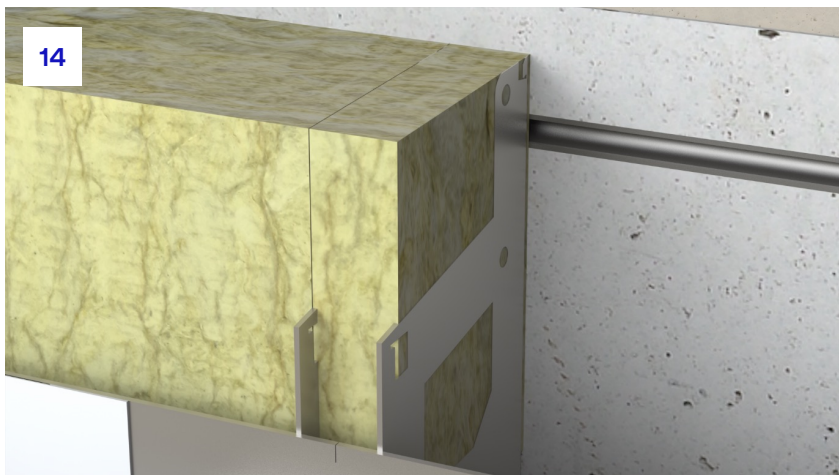

**14.** A further piece of insulation should be installed within the bracket ensuring it fully meets the adjacent insulation.

# Intex™ 4-in-1 Masonry Support System

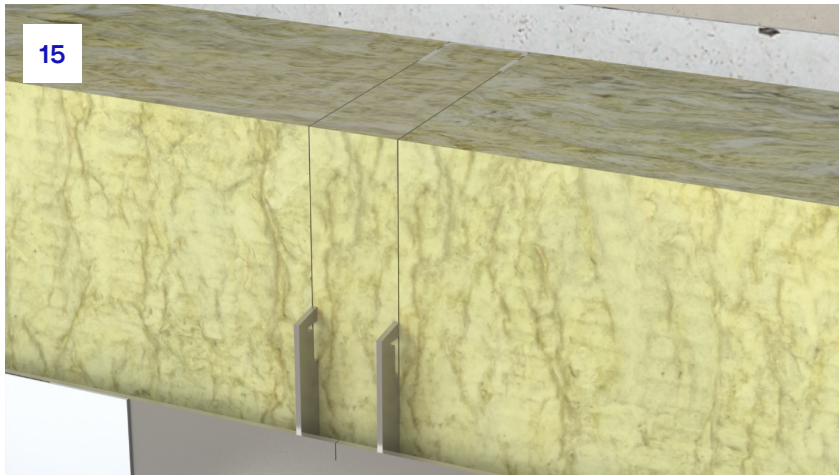

**15.** To the next side of the bracket, a piece of insulation should be installed again up to the bracket to ensure continuity.

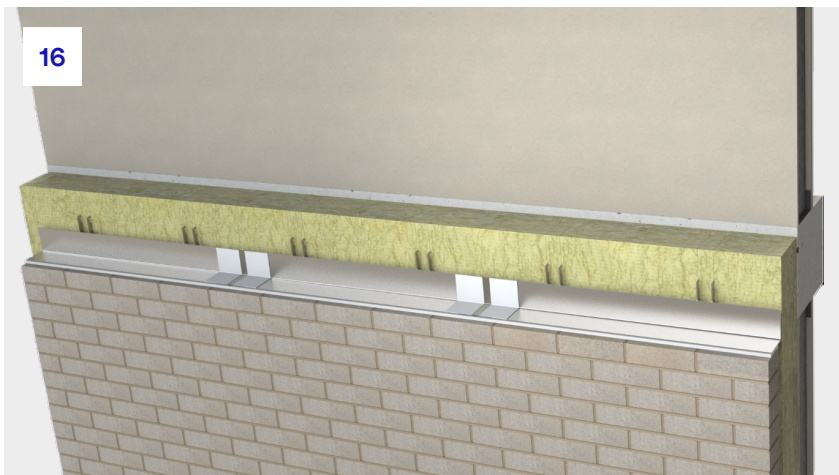

**16.** When complete, there should be a solid face of insulation across the façade, creating a continuous face for the rear intumescent to expand against.

# Intex™ 4-in-1 Masonry Support System

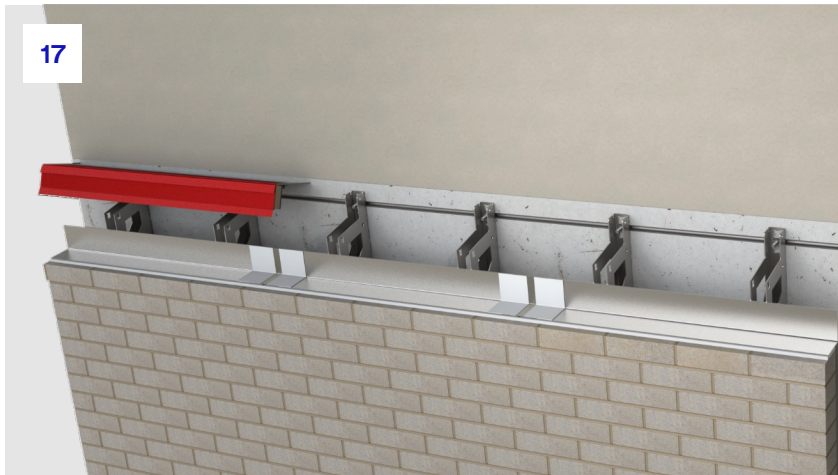

**17.** Once the insulation is in place, it is time to start the installation of the trays. For this section, the insulation has been removed from the images to help with clarity. The relevant first tray should be lined up with the adjoining vertical barrier or structure as per project-specific details. The rear section of the tray should be lined up with the slots in the tops of the brackets.

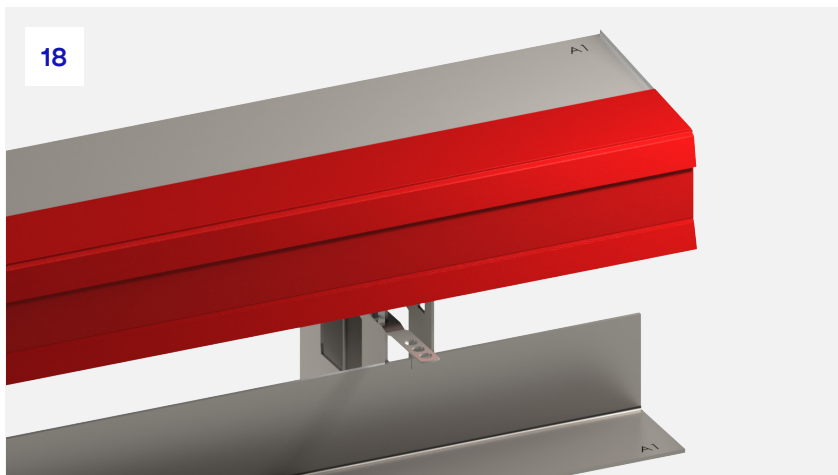

**18.** Each tray has a reference number which will match both the installation drawing, as well as the angle beneath it. This is clearly etched on both the angle as well as the corresponding tray to assist with installation.

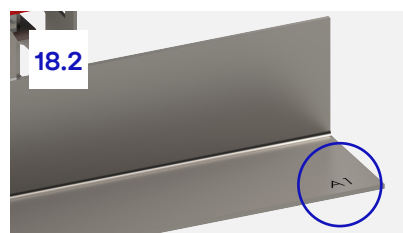
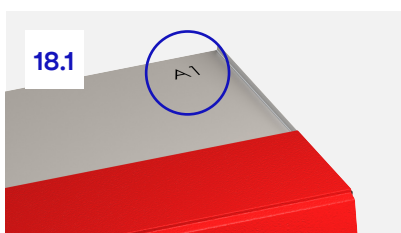

# Intex™ 4-in-1 Masonry Support System

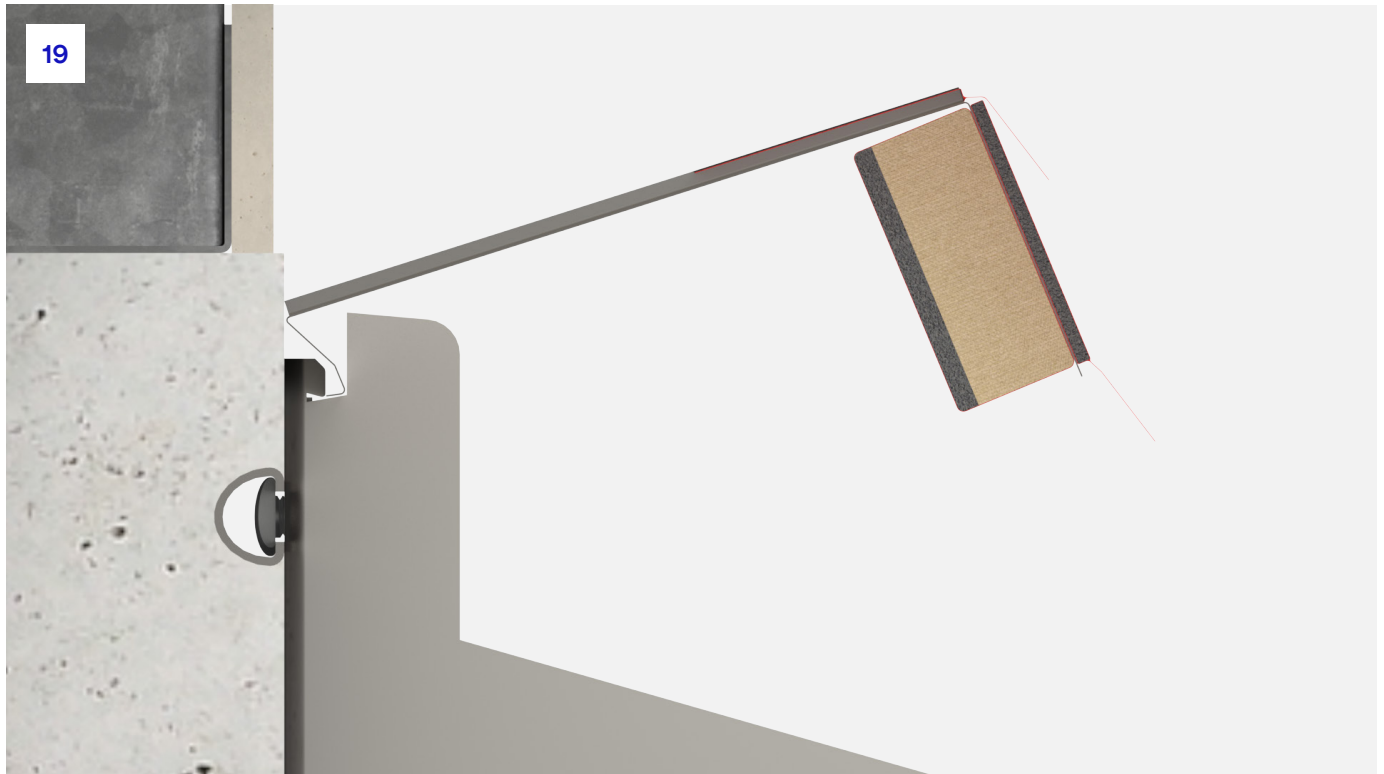

**19.** The tray should be tilted towards the vertical to allow the formed section to sit into the bracket notches.

# Intex™ 4-in-1 Masonry Support System



**20.** The bottom lip of the tray section should be pushed fully into the bracket notch to its rearmost face. The bracket notches are specially designed to match the profile of the tray.



**21.** Once inserted into the slot, the tray can be rotated around to meet the top of the bracket notch and hold it securely in place.

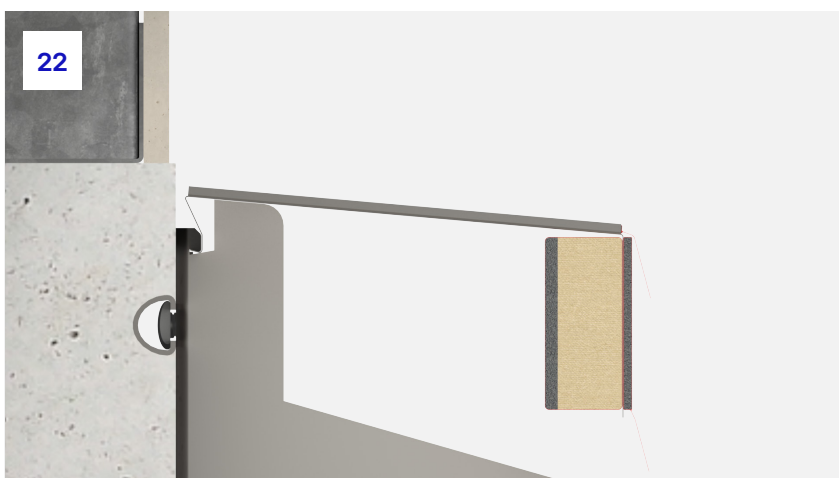

**22.** Once in place, the front face of the barrier should be parallel to the structure. This ensures any moisture which may fall onto the tray is directed towards the external face of the cavity.

# Intex™ 4-in-1 Masonry Support System

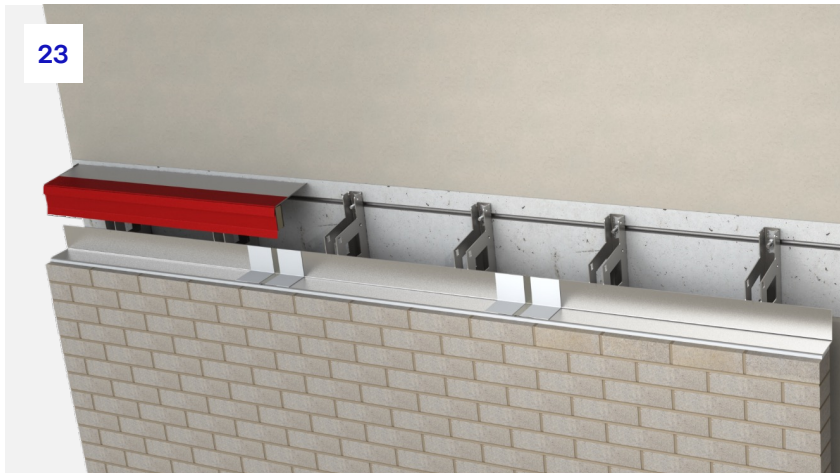

**23.** The tray must be inserted into all brackets along its length to ensure it is fully fixed in place.

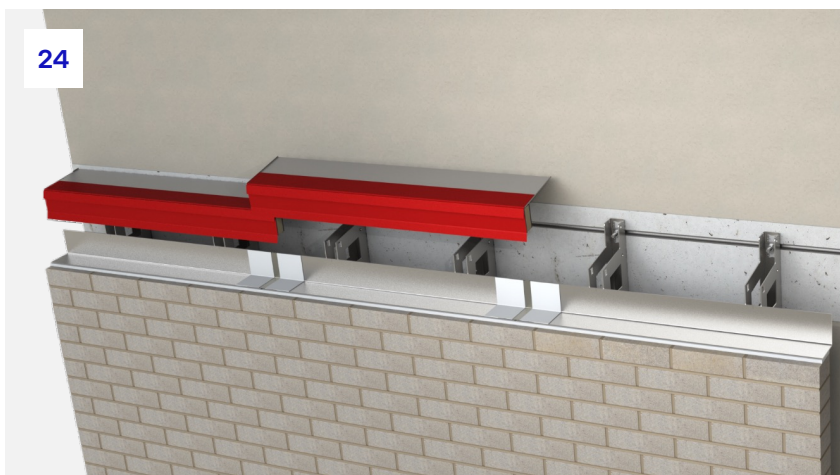

**24.** The next tray can then be placed on top with a minimum of **80mm** overlap between components. Horizontal tolerance in the system is given by sliding the tray along the bracket slot detail.

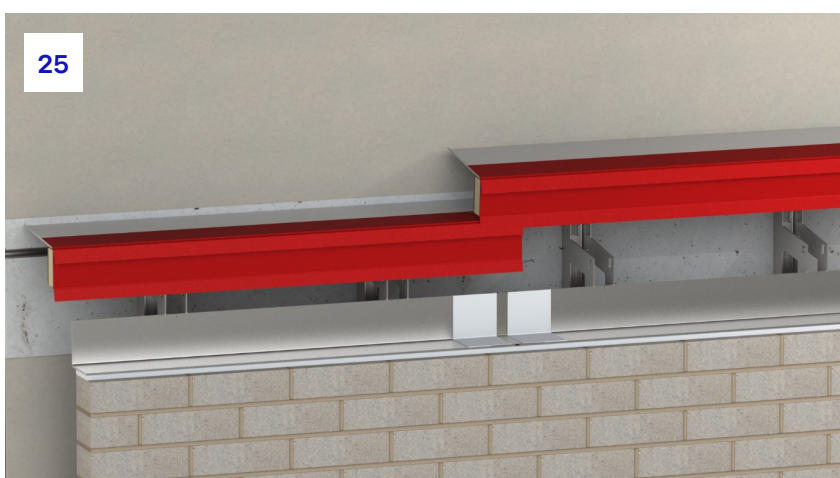

**25.** Once the second barrier is sat on top in the required position, ensuring a minimum overlap of **80mm**, mark the rear barrier where the two barriers meet.

# Intex™ 4-in-1 Masonry Support System



26

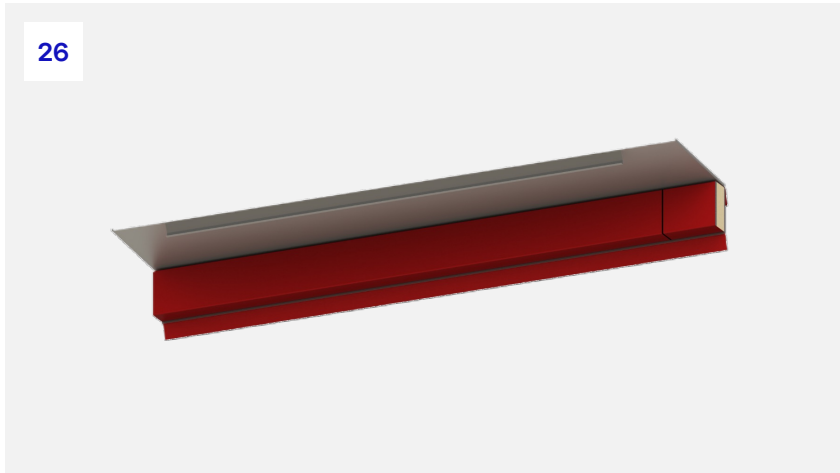

**26.** The mark should be continued around the rear section of the barrier so it is clear where the barrier needs to be cut.

27

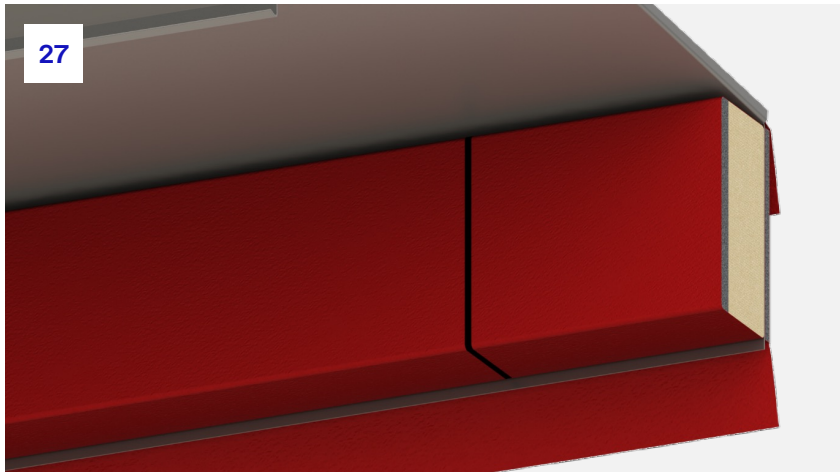

**27.** By creating a clear mark, this ensures cutting is easy to achieve and reduces the risk of errors.

28

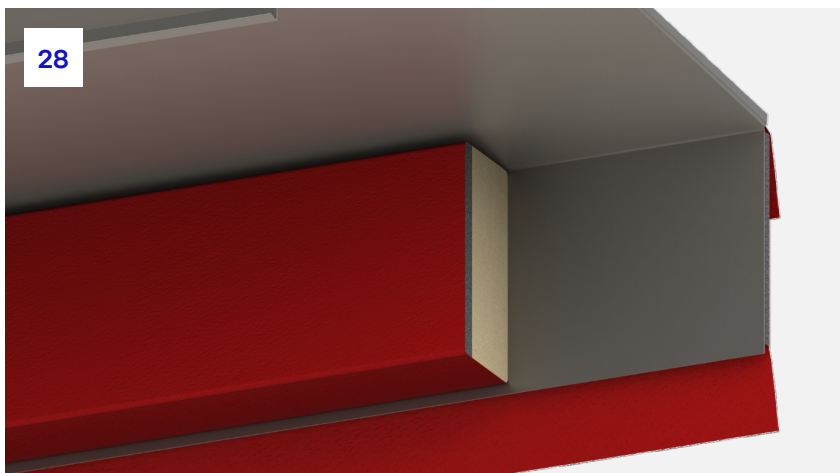

**28.** The rear barrier **ONLY** should then be cut at this location.



# Intex™ 4-in-1 Masonry Support System

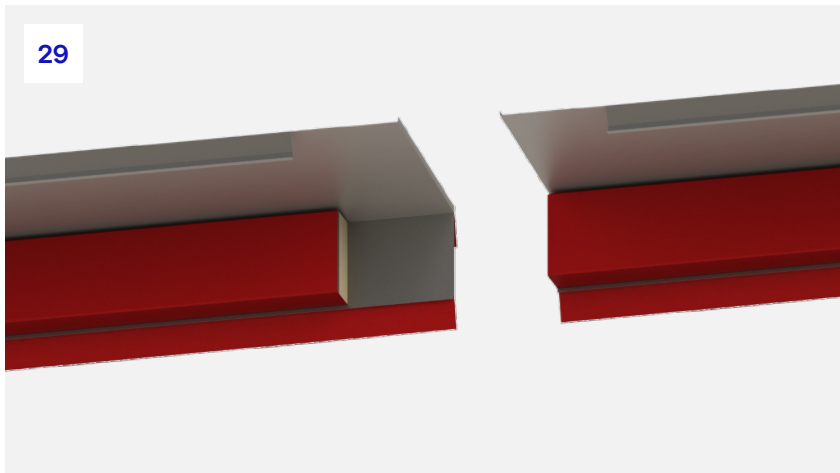

**29.** You will now have a rear barrier with a full end attached to the brackets and an additional cut piece ready for installation.

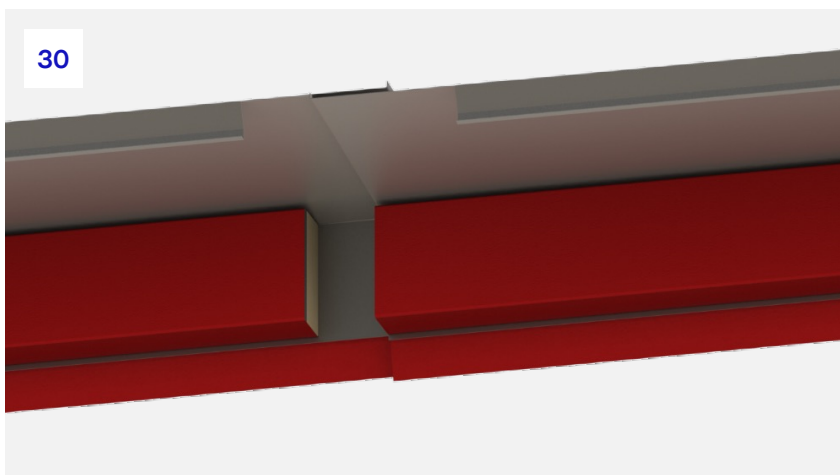

**30.** Once the rear barrier is cut the two barriers can be pushed together. For the rear section, the two barriers should be fully butted together to ensure they provide a continuous stop against heat and flame.

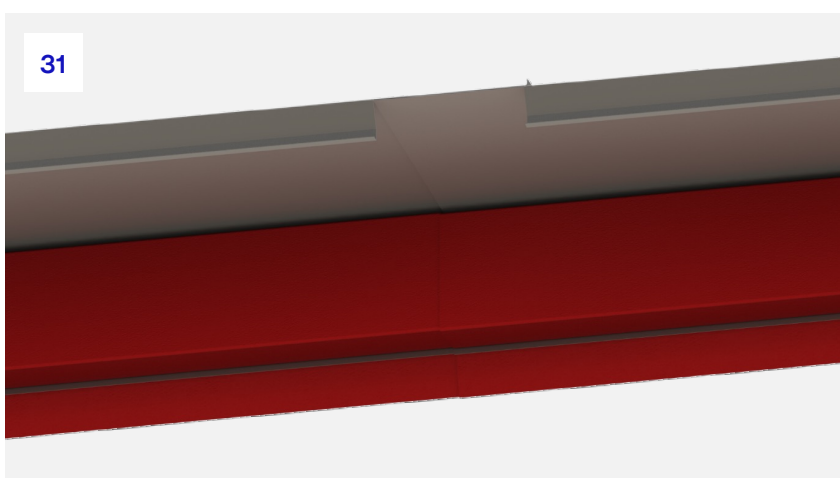

**31.** It is imperative that the barriers are fully butted together at this stage.

# Intex™ 4-in-1 Masonry Support System

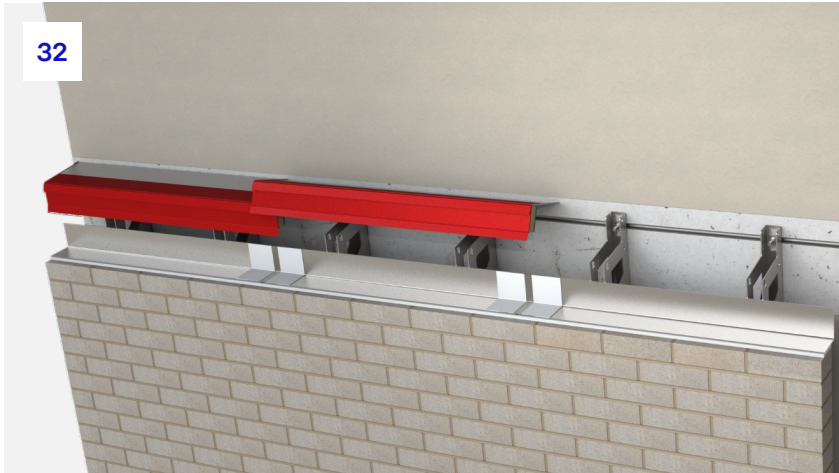

**32.** In the same manner as the first tray, the formed section of the tray can be placed into the bracket notches and rotated into place. See pages 13 and 14 for more details.

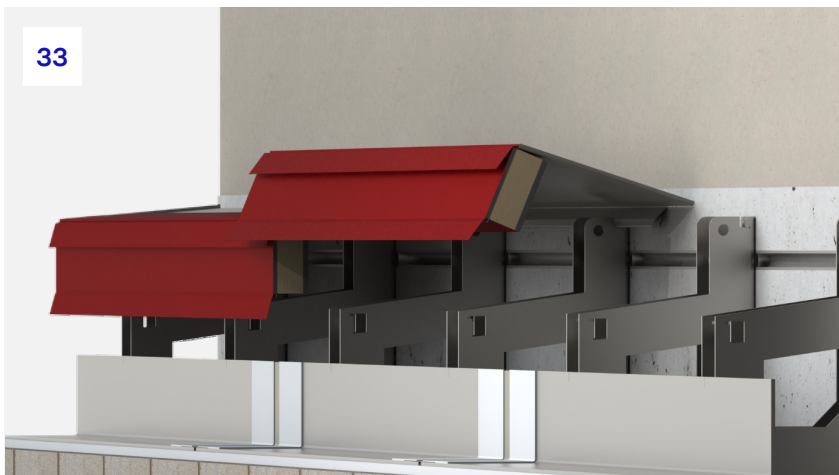

**33.** The bottom lip of the tray section should be pushed fully into the bracket notch to its rearmost face. The bracket notches are specially designed to match the profile of the tray.

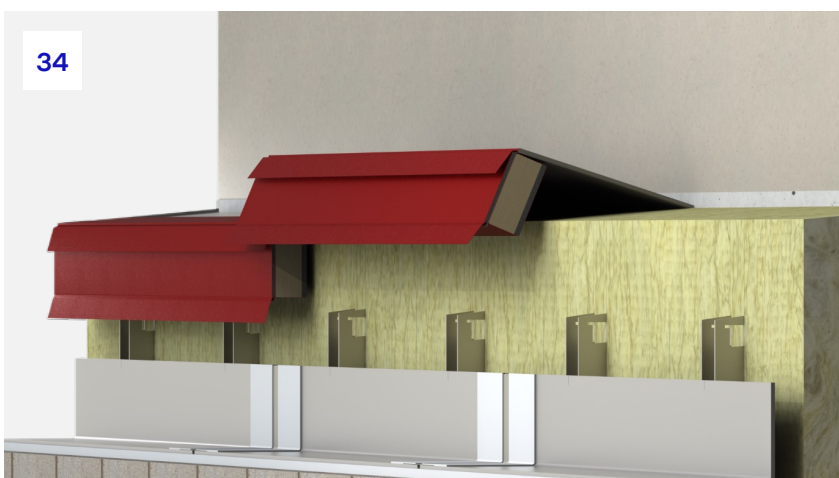

**34.** The tray can be fitted around the insulation ensuring a tight fit between all components.

# Intex™ 4-in-1 Masonry Support System

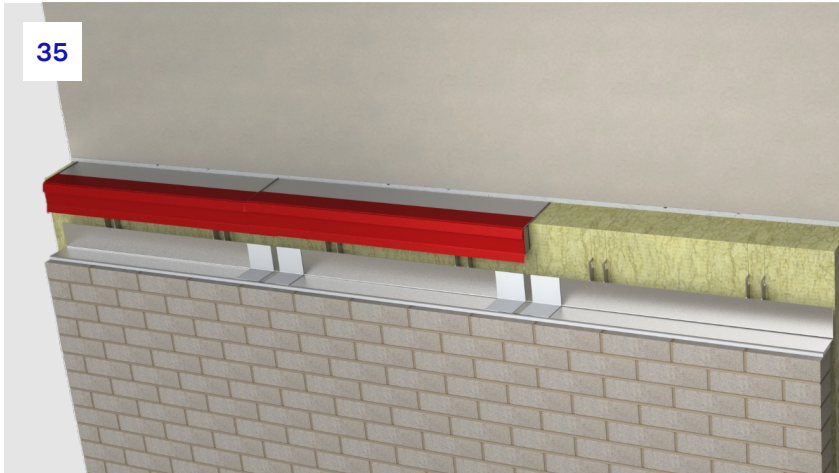

**35.** Once in place, to ensure rear components are touching, the second barrier must be slid toward the first barrier, utilising the system tolerance.

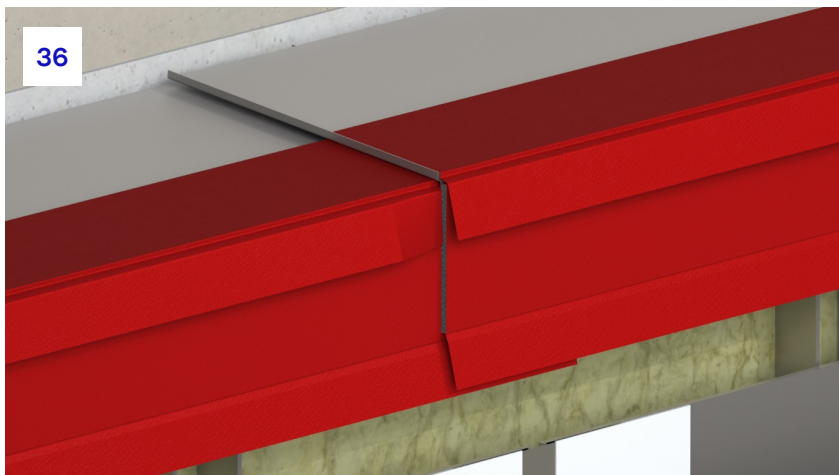

**36.** For both the top and front sections of the tray barrier, the second tray should sit on top of the lower barriers as shown in the image. This ensures continuity in the case of fire.

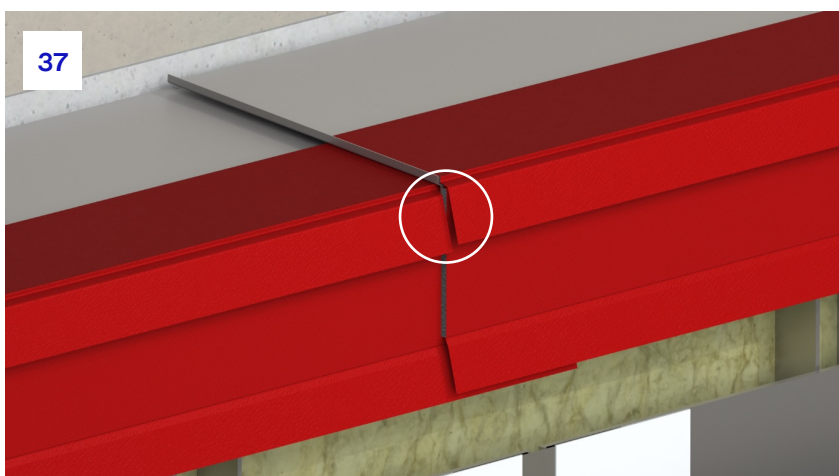

**37.** Once in place, the top wing should be cut tight to the tray lip to ensure it can move freely in the case of fire.

# Intex™ 4-in-1 Masonry Support System

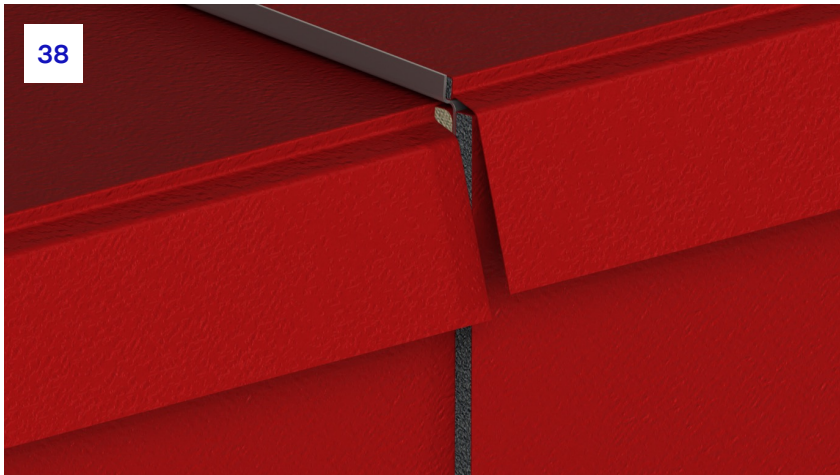

**38.** Once cut, the wing will be free to expand in the case of fire.

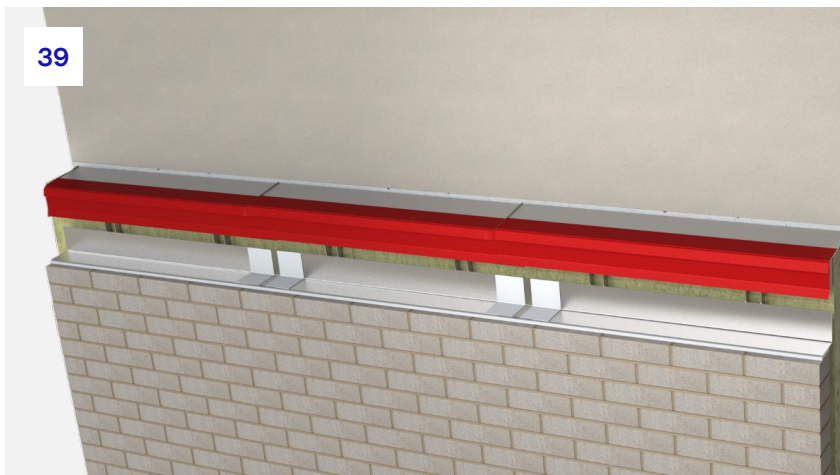

**39.** Once the second tray is in place, the same process can be followed for any remaining trays, ensuring the references match between the drawing, angle, and tray.

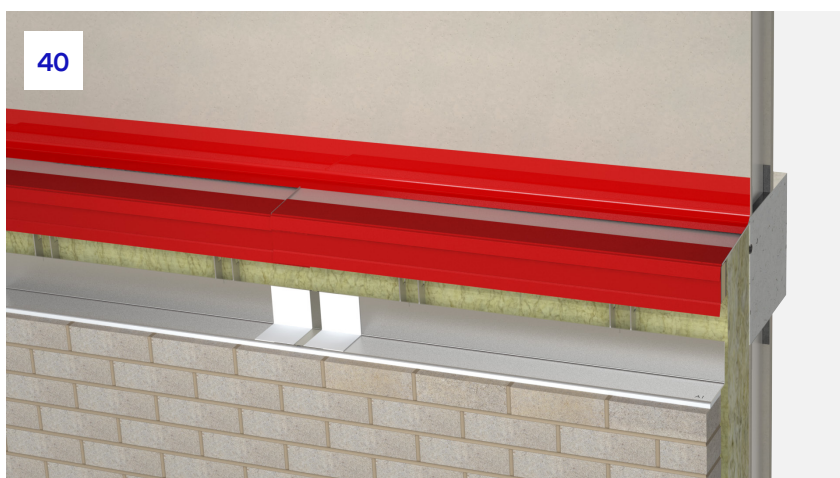

**40.** To allow for typical construction tolerances, a gap is left between the rear of the tray and the internal structure. A membrane or tape should be used to cover this gap, subject to approval from the design team to ensure no moisture can continue down the rear of the façade.

# Intex<sup>™</sup> 4-in-1 Masonry Support System

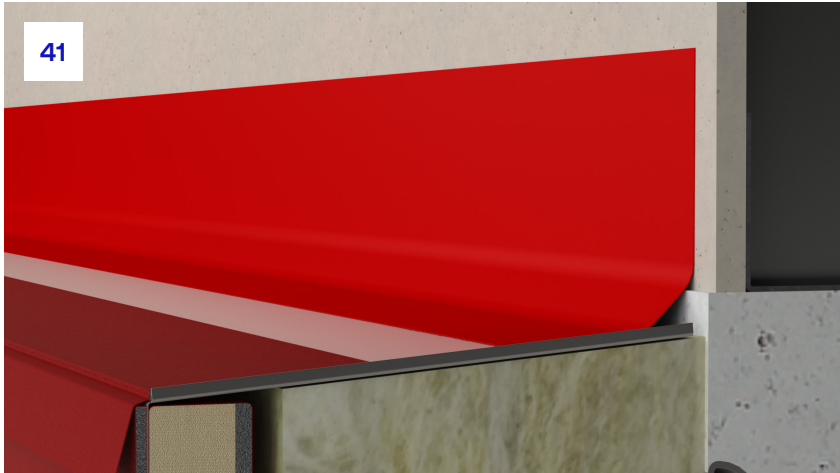

**41.** The membrane/tape should be fully sealed against both the internal structure as well as the Intex<sup>™</sup> top tray as per manufacturer's guidelines.



**42.** The system can be used with ACS stainless steel weep vents. These should be used on fresh mortar ensuring any moisture collected on the tray is ejected from the cavity. The lipped section of the weep vent should sit proud of the brickwork to ensure moisture is successfully ejected.



**43.** Mortar should be placed into the remainder of the vertical mortar joint to ensure the weep vent is sufficiently held in place.

# Intex™ 4-in-1 Masonry Support System

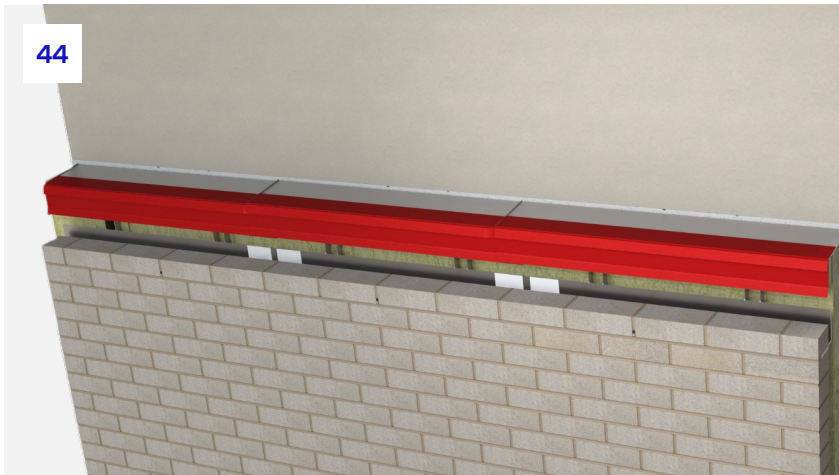

44

**44.** Centres for the weep vents should be specified by the project design team ensuring that water can be sufficiently ejected.



45

**45.** Brickwork may continue up the façade following industry guidance around maximum builds per day.

# Intex™ 4-in-1 Masonry Support System

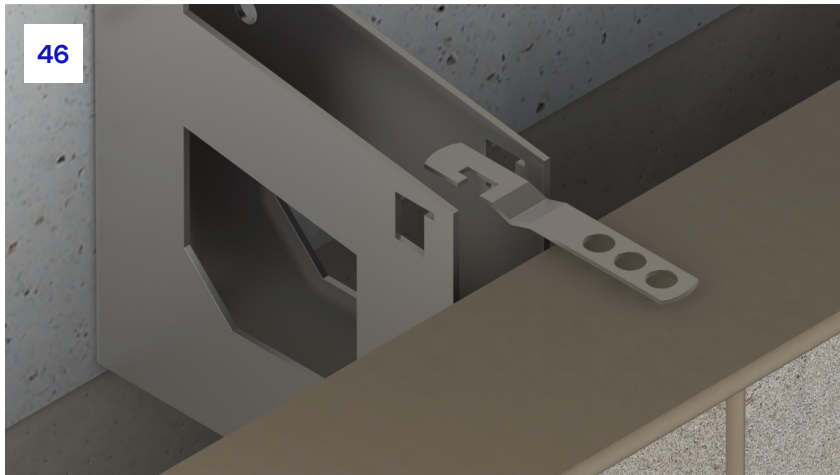

**46.** To ensure restraint of the masonry panel, the brackets include specially designed notches to allow Intex™ ties to be installed. The tie should be clipped into the bracket with the tie drip pointing downwards. This ensures that any moisture that may land on the tie is not carried towards the internal face of the cavity. The bracket notch is larger at the top and allows the tie to easily be clipped in.

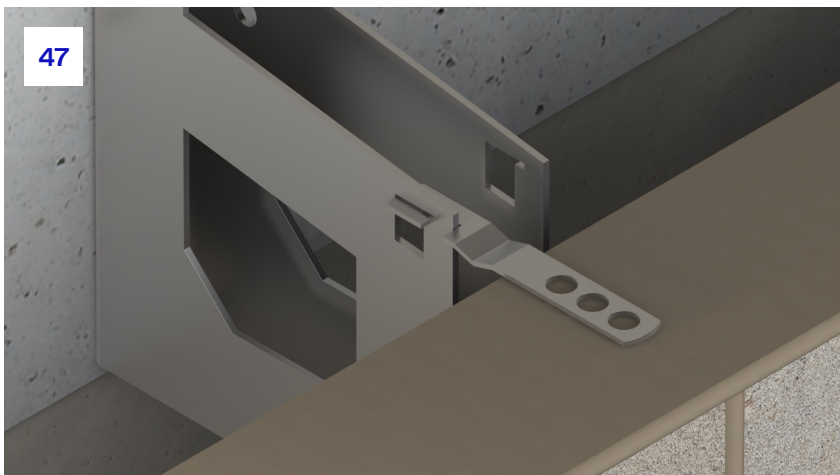

**47.** The Intex™ tie should then be lowered down the bracket notch into the lower section. Tolerance is within the notch to allow for both standard bricks as well as pistol bricks.

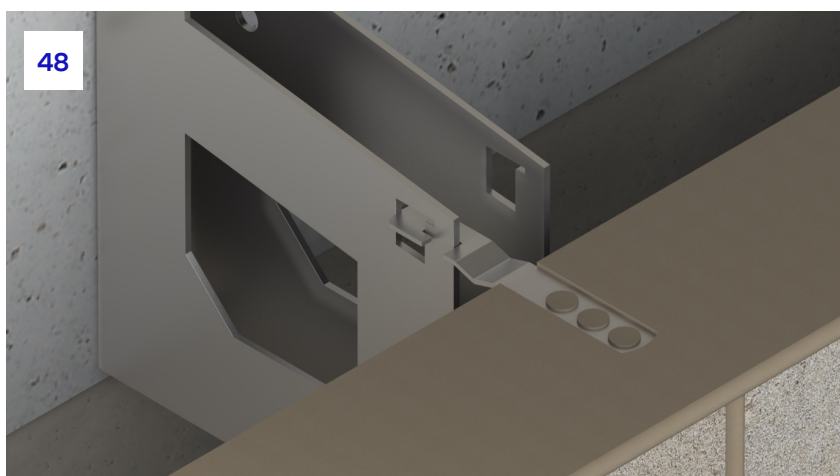

**48.** The Intex™ tie should be pushed downwards and embedded into the mortar ensuring it is pushed into the centre of the joint.

# Intex™ 4-in-1 Masonry Support System

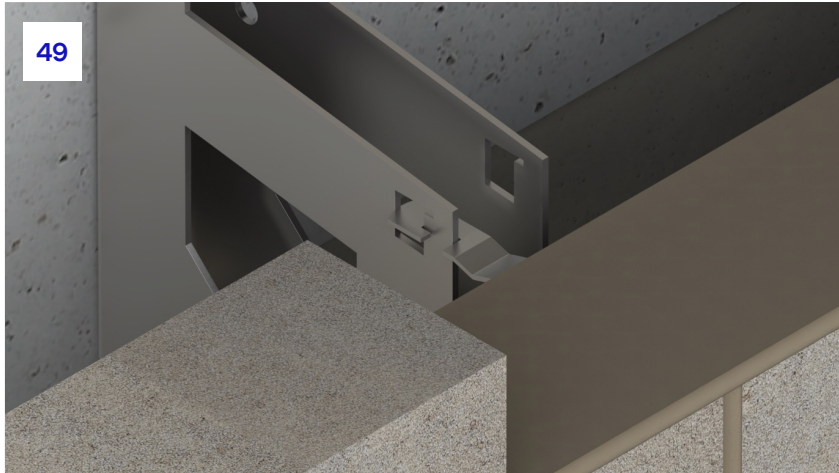

**49.** Further mortar should be placed on top of the tie to ensure it will have sufficient restraint against pull out. The next course of bricks can then be placed on the top of the mortar.

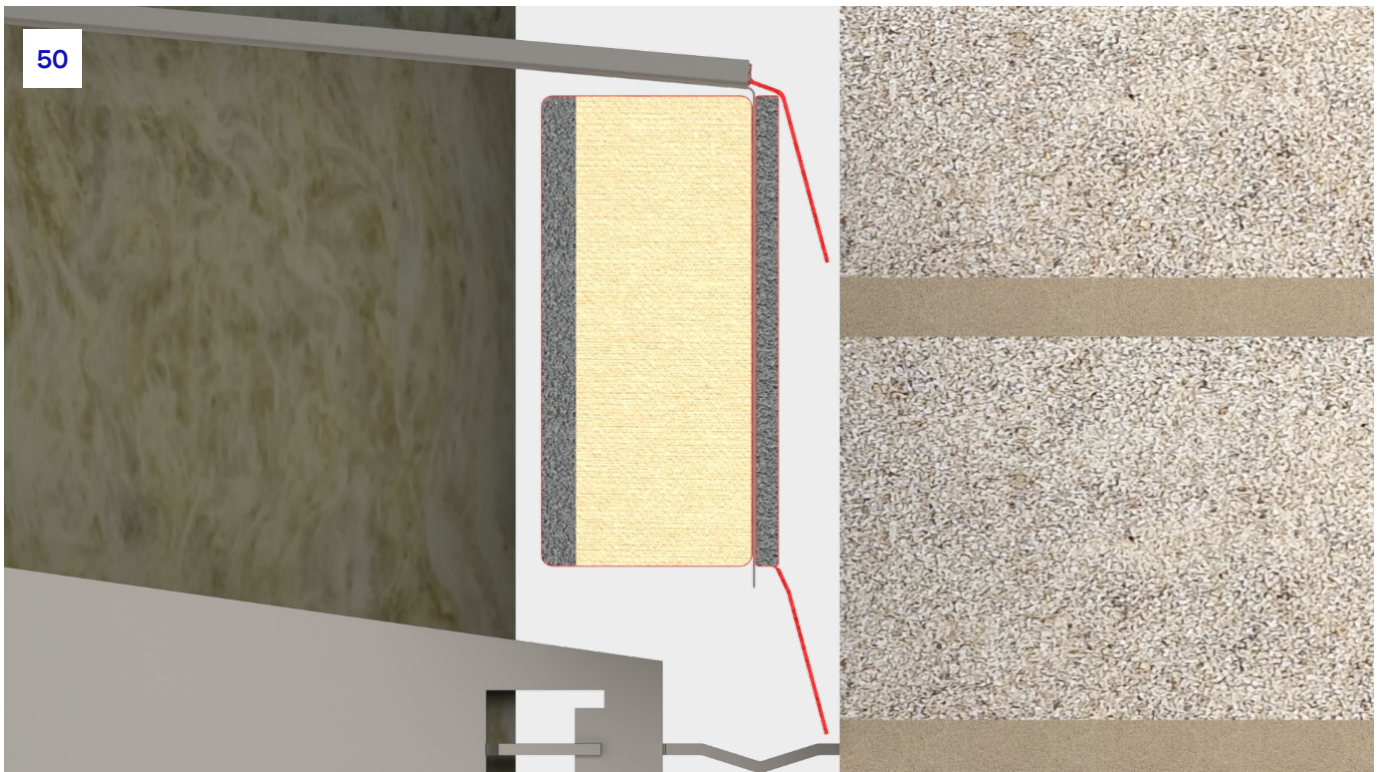

**50.** As brickwork continues up the façade, it is imperative that the barrier wings are left free within the cavity space. Under heat and fire, the wing expands into the brickwork to assist with intumescent expansion.



# Intex<sup>™</sup> 4-in-1 Masonry Support System

---

# Corner Installation

# Intex™ 4-in-1 Masonry Support System



Check for updates

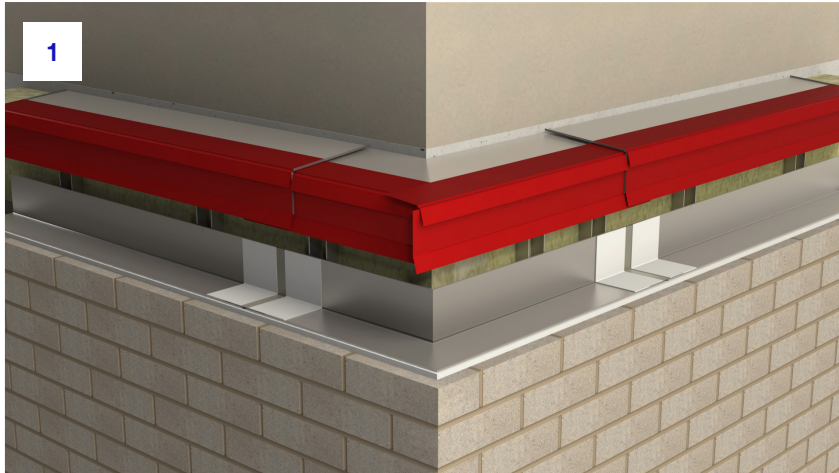

1. This section of the installation guide contains information specific to the installation of Intex™ 4-in-1 Masonry Support corners. The general principles of the main installation guide should be followed whilst following the guidance around corner component installation.



2. If there is any uncertainty during the installation process, work must stop and advice be sought on how to continue correctly. Project-specific drawings will be supplied showing specific component references as well as section details containing information such as fixing location within the substrate edge. These drawings should be followed alongside this installation guide to ensure a compliant installation for the product.

# Intex™ 4-in-1 Masonry Support System

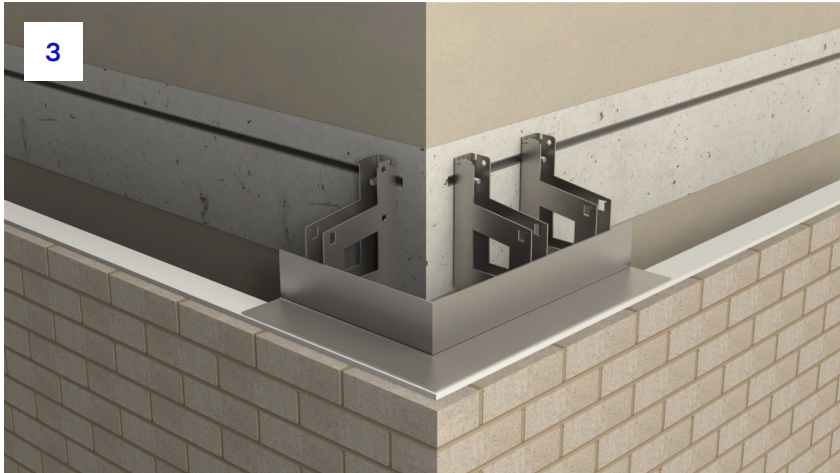

**3.** Refer to the relevant ACS approval drawing and look for the required reference for the corner piece to be installed. Find this piece within the delivered Intex™ 4-in-1 Masonry Support and locate it in the relevant area of the building. Where required, the angle should be located above the horizontal movement joint following levels dictated by the design team. There should always be a gap left to allow for expansion of the masonry panel below. Site-specific drawings will give the required level for the angle to be set at.

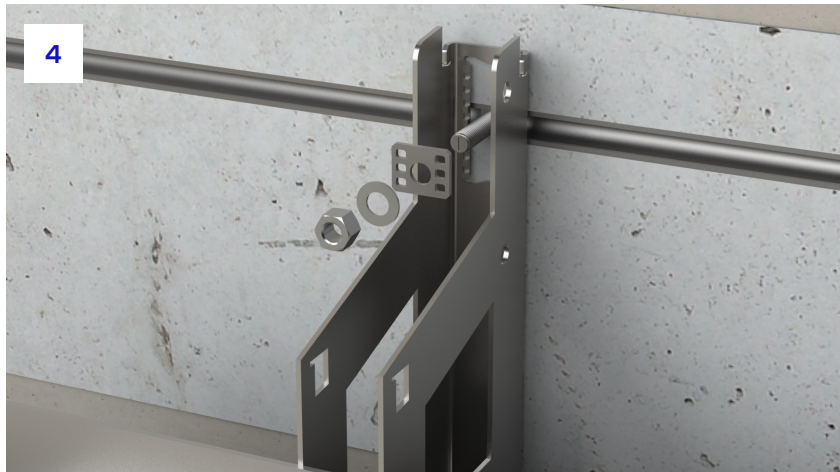

**4.** A fixing should be inserted through the bracket into the structure. For reference, ACS 31-21 cast in channel has been shown; however, please follow fixing specific installation instructions. Upon this fixing should be located an alpha adjustment washer which will allow for vertical tolerance, as well as a form B washer and hex head nut.

# Intex<sup>™</sup> 4-in-1 Masonry Support System

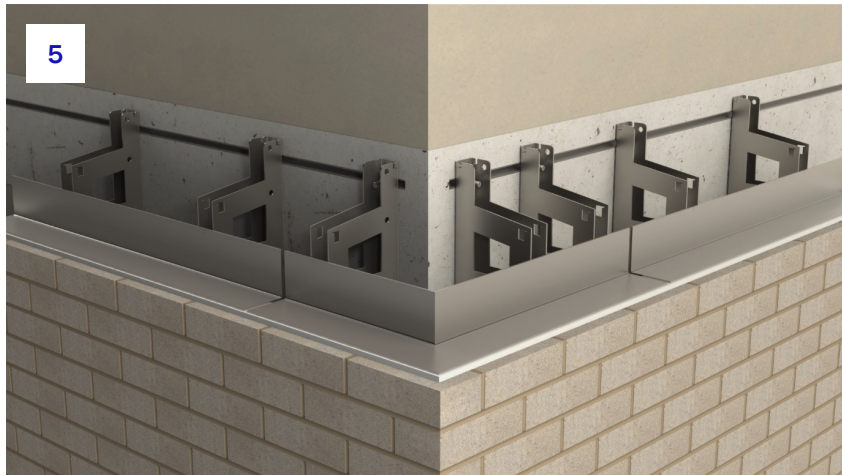

5. Continue to install further pieces of Intex<sup>™</sup> brackets and angle following ACS approval drawings, allowing for around a 10mm gap between units. Each angle should be levelled to the value shown upon the ACS drawings. A string line is commonly used to assist with installation.

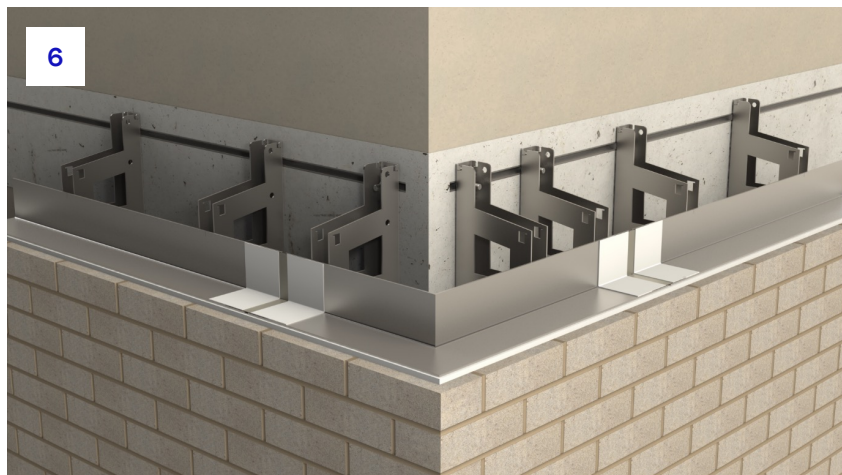

6. Install Intex<sup>™</sup> jointing pieces over all gaps between angles. This requires a double-sided ACS Butyl tape each side of the gap, an Intex<sup>™</sup> jointing piece, and a single-sided ACS Butyl tape for each side of the jointing piece. For further details, please see the main section of the installation guide.

# Intex™ 4-in-1 Masonry Support System

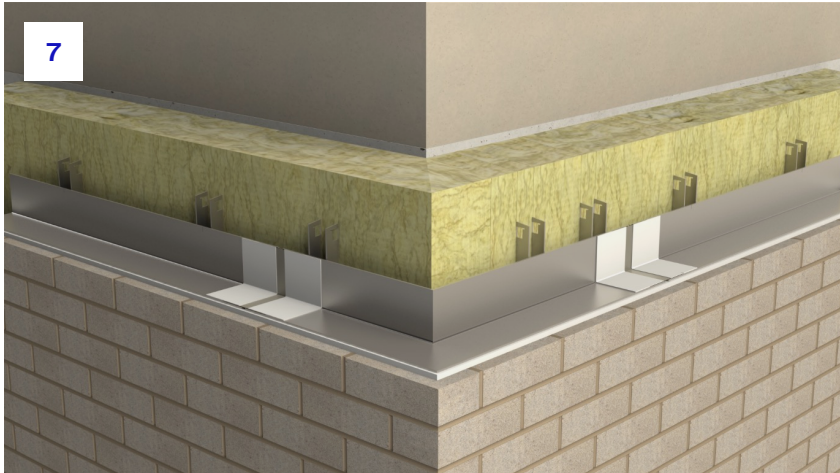

**7.** Thermal insulation should be tightly installed both between the bracket legs as well as between brackets ensuring it is tight up against all components to create a continuous face for the rear intumescent to expand against. For further details, please see the main section of the installation guide.

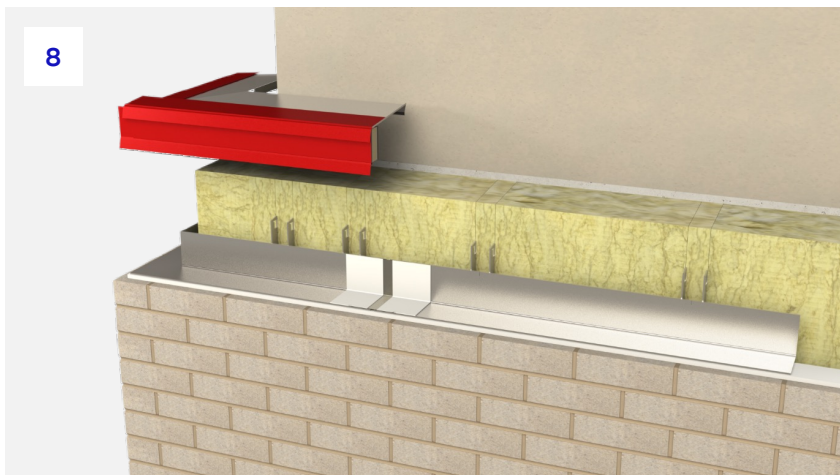

**8.** Once the insulation is in place, it is time to start the installation of the trays. The corner piece should be installed first and lined up with the brackets located below.

# Intex™ 4-in-1 Masonry Support System

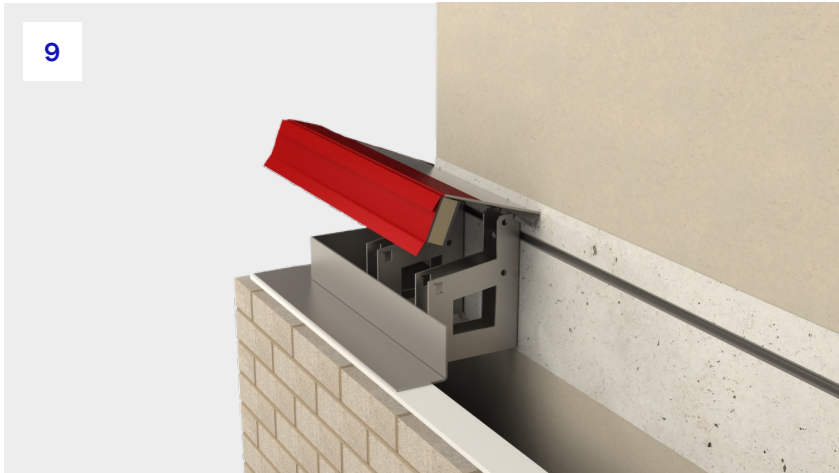

9. The right-hand side of the corner tray contains the same formed section as the straight trays to locate within the bracket notches. Each tray has a reference number which will match both the installation drawing, as well as the angle beneath it.

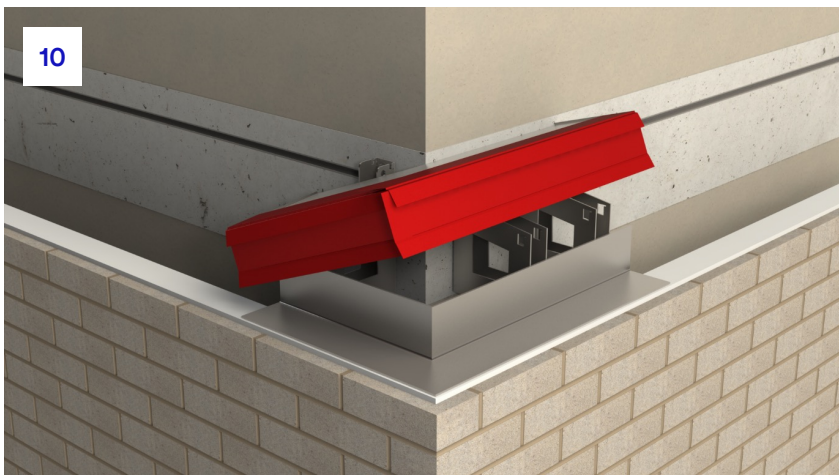

10. The tray should be rotated around to allow the formed section to be inserted into the bracket notches. The tray can be temporarily slid to the left to allow for easy rotation.

# Intex™ 4-in-1 Masonry Support System



**11.** The tray should be tilted towards the vertical to allow the formed section to sit into the bracket notches.



**12.** The bottom lip of the tray section should be pushed fully into the bracket notch to its rearmost face. The bracket notches are specially designed to match the profile of the tray.



**13.** Once inserted into the slot, the tray can be rotated around to meet the top of the bracket notch and hold it securely in place.

# Intex™ 4-in-1 Masonry Support System

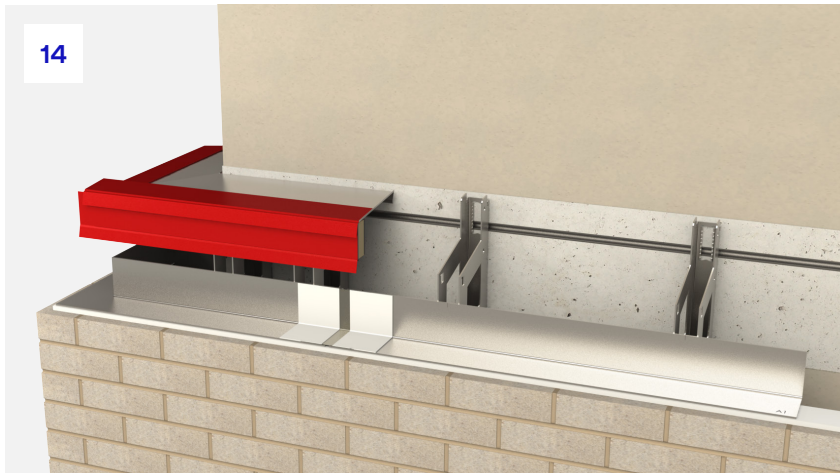

**14.** The tray can now be slid to the right within the bracket slots until the return tray lip meets the left-hand side bracket notch.



**15.** On the left-hand side of the corner tray, the formed section is just required to sit within the gap of the bracket notch allowing the tray to be restrained in place laterally.

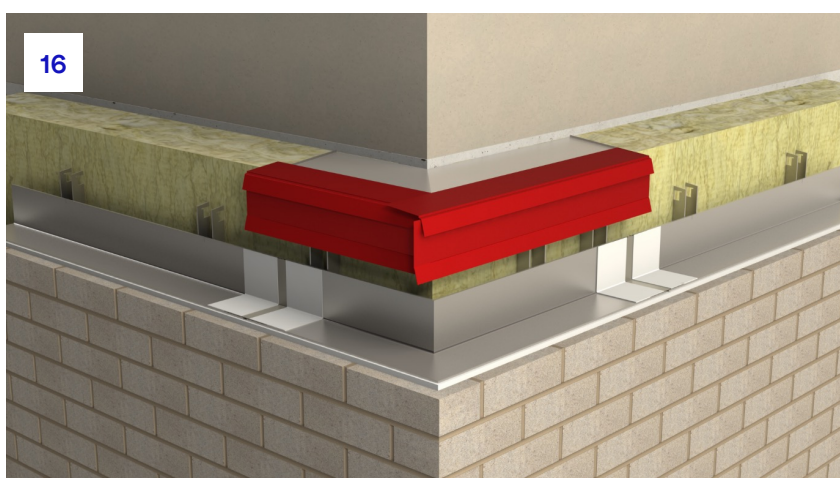

**16.** Once in place, the tray will be tight against the insulation and sat within all bracket notches.



# Intex™ 4-in-1 Masonry Support System

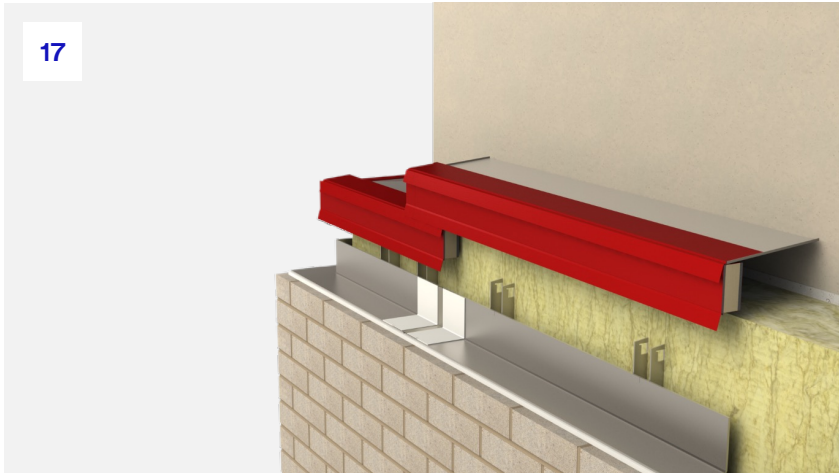

**17.** The next tray can then be placed on top with a minimum of 80mm overlap between components. Horizontal tolerance in the system is given by sliding the tray along the bracket slot detail. Once the second barrier is sat on top in the required position, ensuring a minimum overlap of 80mm, mark the rear barrier where the two barriers meet.

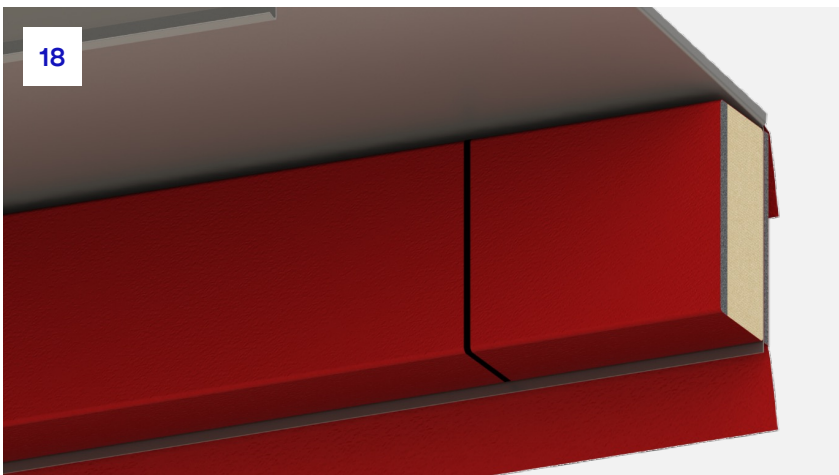

**18.** The mark should be continued around the rear section of the barrier so it is clear where the barrier needs to be cut. By creating a clear mark, this ensures cutting is easy to achieve and reduces the risk of errors.

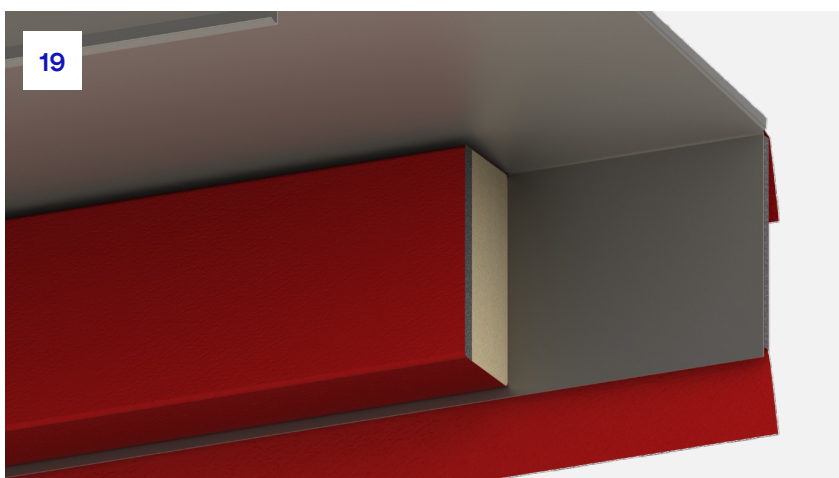

**19.** The rear barrier **ONLY** should then be cut at this location.

# Intex™ 4-in-1 Masonry Support System

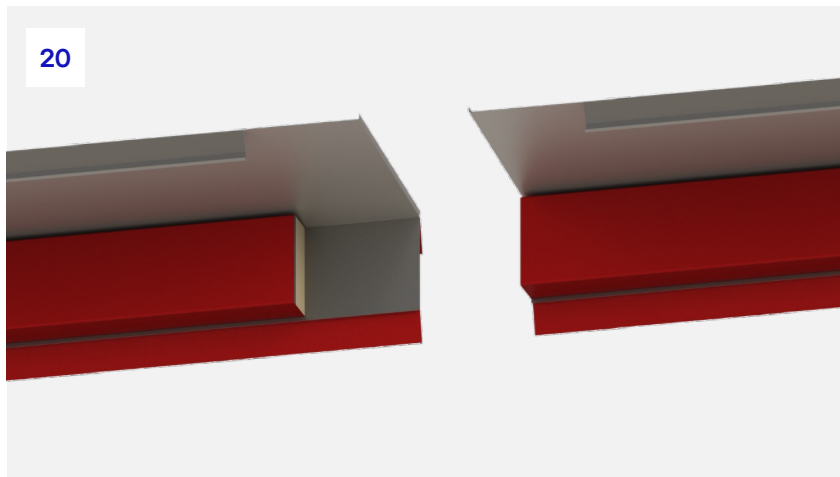

**20.** You will now have a rear barrier with a full end attached to the brackets and an additional cut piece ready for installation.

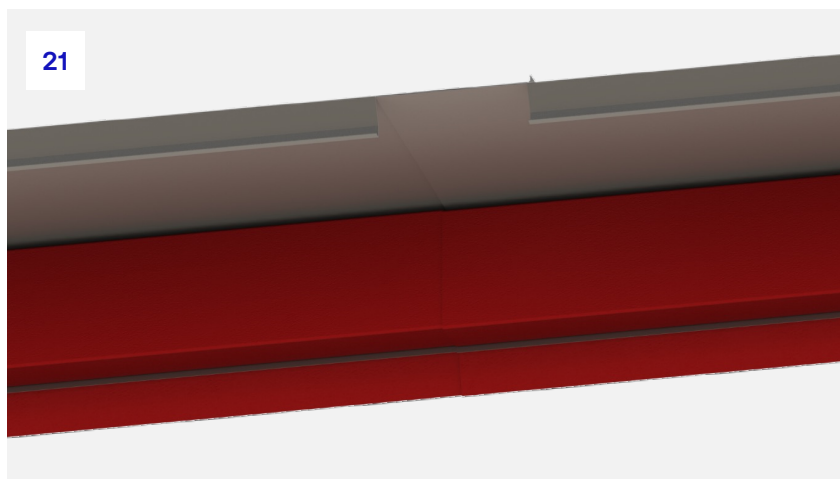

**21.** Once the rear barrier is cut the two barriers can be pushed together. For the rear section, the two barriers should be fully butted together to ensure they provide a continuous stop against heat and flame. It is imperative that the barriers are fully butted together at this stage.

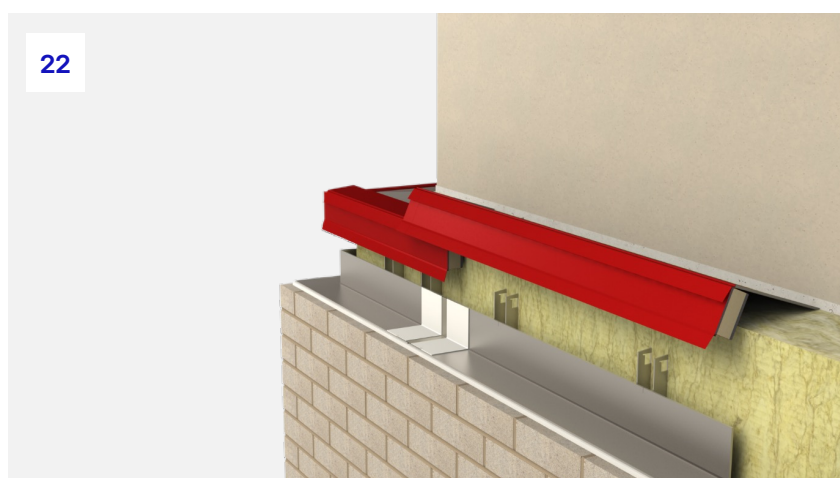

**22.** In the same manner as the first tray, the formed section of the tray can be placed into the bracket notches and rotated into place. The bottom lip of the tray section should be pushed fully into the bracket notch to its rearmost lip. The bracket notches are specially designed to match the profile of the tray. The tray can be fitted around the insulation ensuring a tight fit between all components.

# Intex™ 4-in-1 Masonry Support System

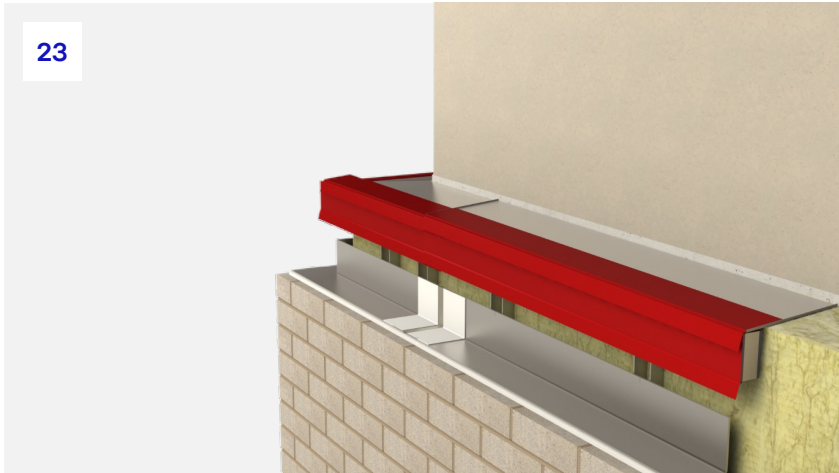

**23.** Once in place, to ensure rear components are touching, the second barrier must be slid toward the first barrier, utilising the system tolerance.

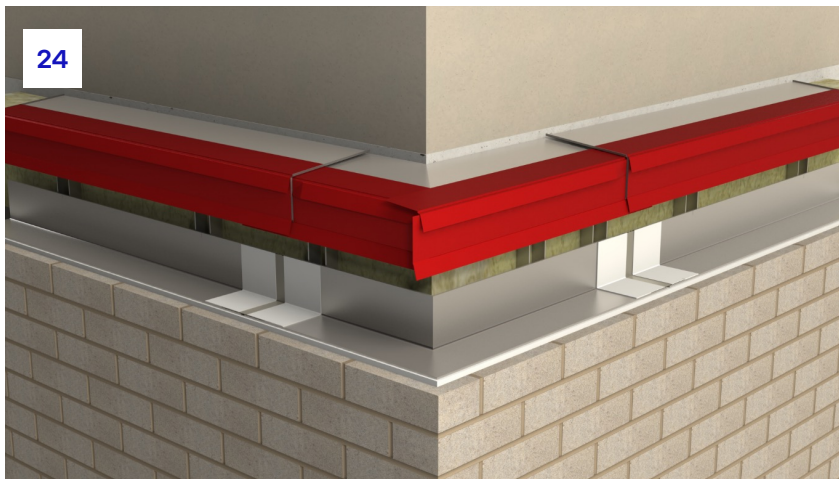

**24.** At this stage the corner wings will project past the corner into the brickwork area.

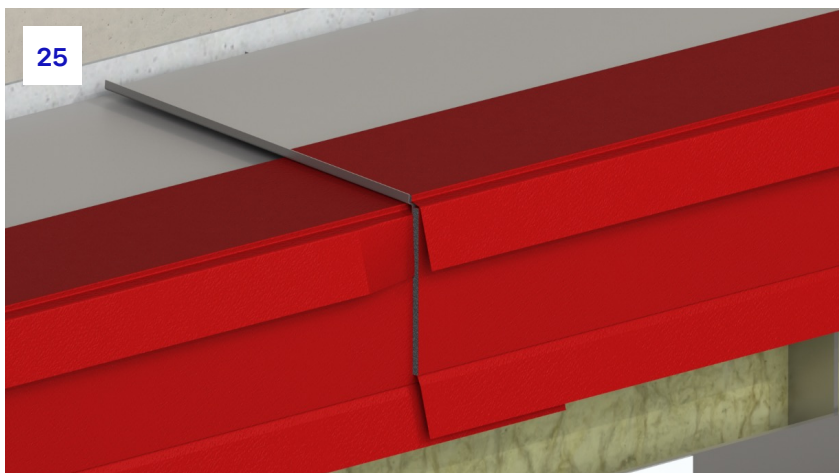

**25.** For both the top and front sections of the tray barrier, the second tray should sit on top of the lower barriers as shown in the image. This ensures continuity in the case of fire.

# Intex™ 4-in-1 Masonry Support System

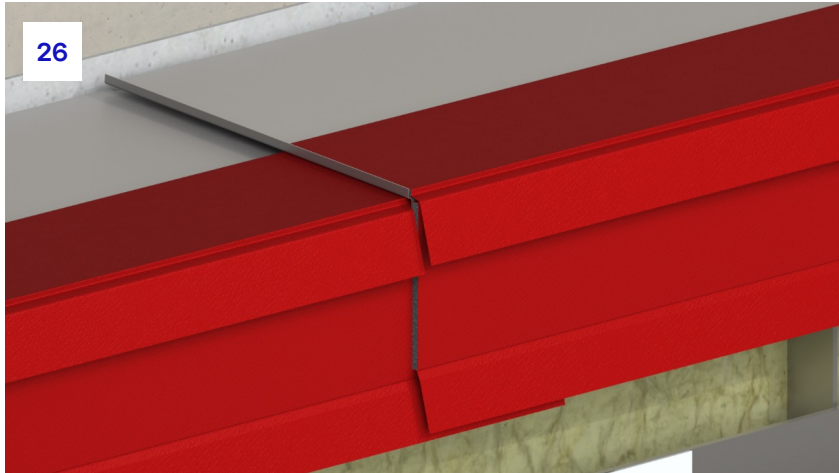

**26.** Once in place, the top wing should be cut tight to the tray lip to ensure it can move freely in the case of fire.

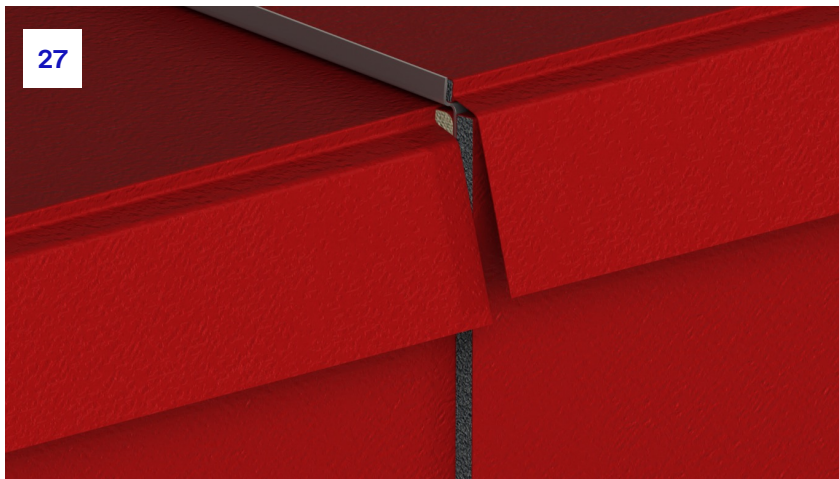

**27.** Once cut, the wing will be free to expand in the case of fire.

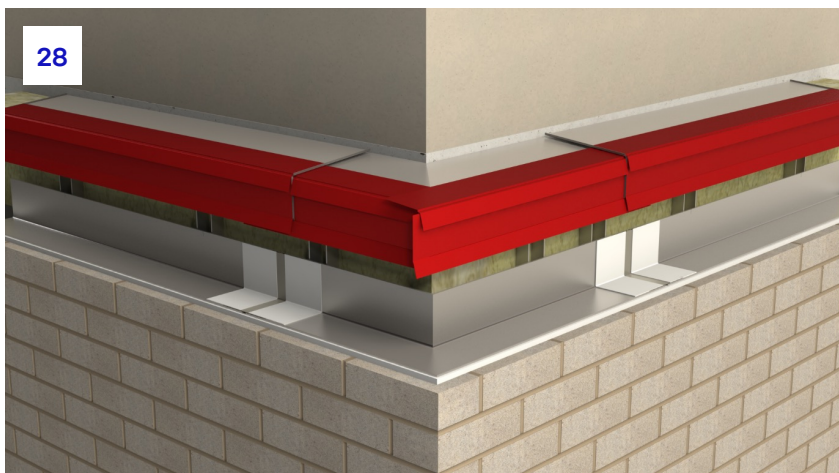

**28.** Once the second tray is in place, the same process can be followed for any remaining trays, ensuring the references match between the drawing, angle, and tray.

# Intex™ 4-in-1 Masonry Support System



**29.** The system can be used with ACS stainless steel weep vents. These should be used on fresh mortar ensuring any moisture collected on the tray is ejected from the cavity. The lipped section of the weep vent should sit proud of the brickwork to ensure moisture is successfully ejected. Mortar should be placed into the remainder of the vertical mortar joint to ensure the weep vent is sufficiently held in place. Centres for the weep vents should be specified by the project design team ensuring that water can be sufficiently ejected. For further details, please see the main section of the installation guide.

# Intex™ 4-in-1 Masonry Support System

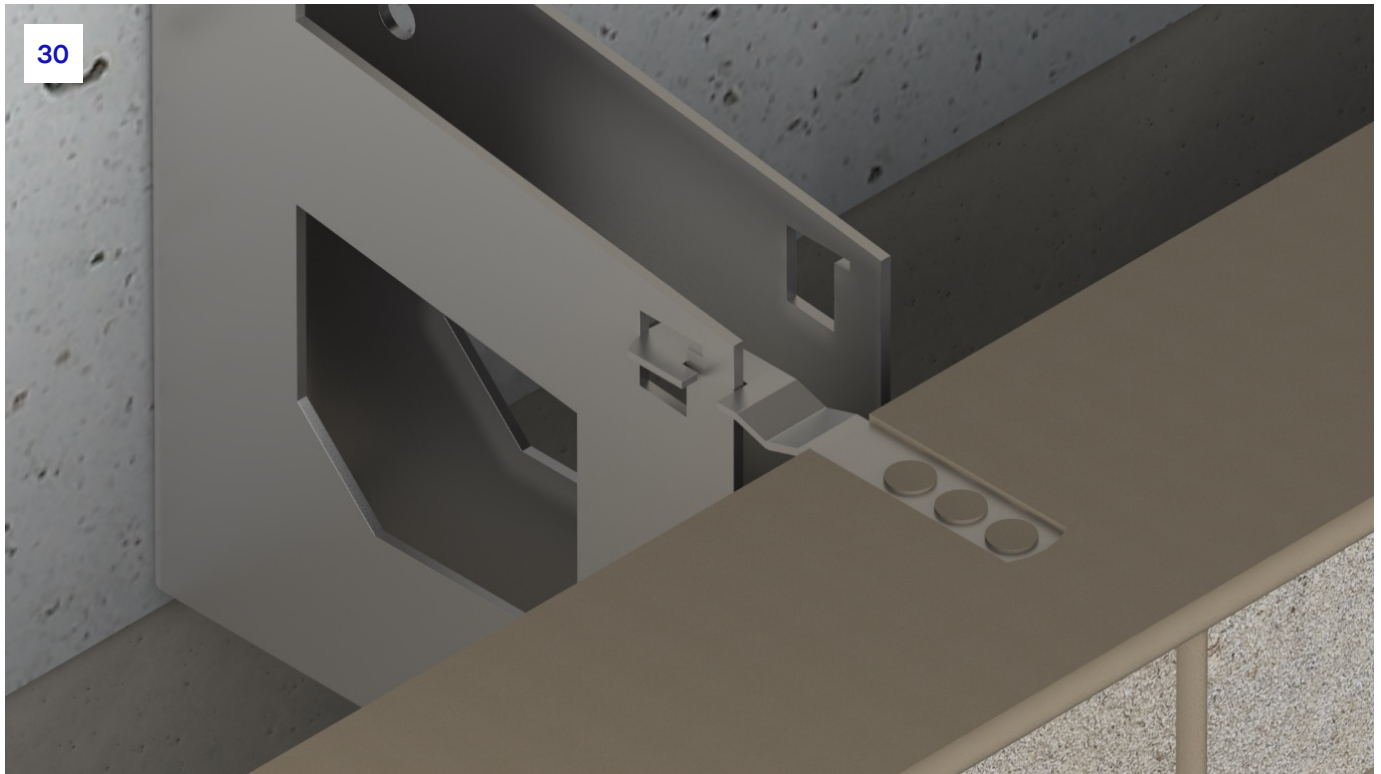

**30.** To ensure restraint of the masonry panel, the brackets include specially designed notches to allow Intex™ ties to be installed. The tie should be clipped into the bracket with the tie drip pointing downwards. This ensures that any moisture that may land on the tie is not carried towards the internal face of the cavity. The bracket notch is larger at the top and allows the tie to be clipped in easily. The Intex™ tie should then be lowered down the bracket notch into the lower section. Tolerance is within the notch to allow for both standard bricks as well as pistol bricks. The Intex™ tie should be pushed into and embedded into the mortar ensuring it is pushed into the centre of the joint. Further mortar should be placed on top of the tie to ensure it will have sufficient restraint against pull out. The next course of bricks can then be placed on the top of the mortar.

# Intex™ 4-in-1 Masonry Support System

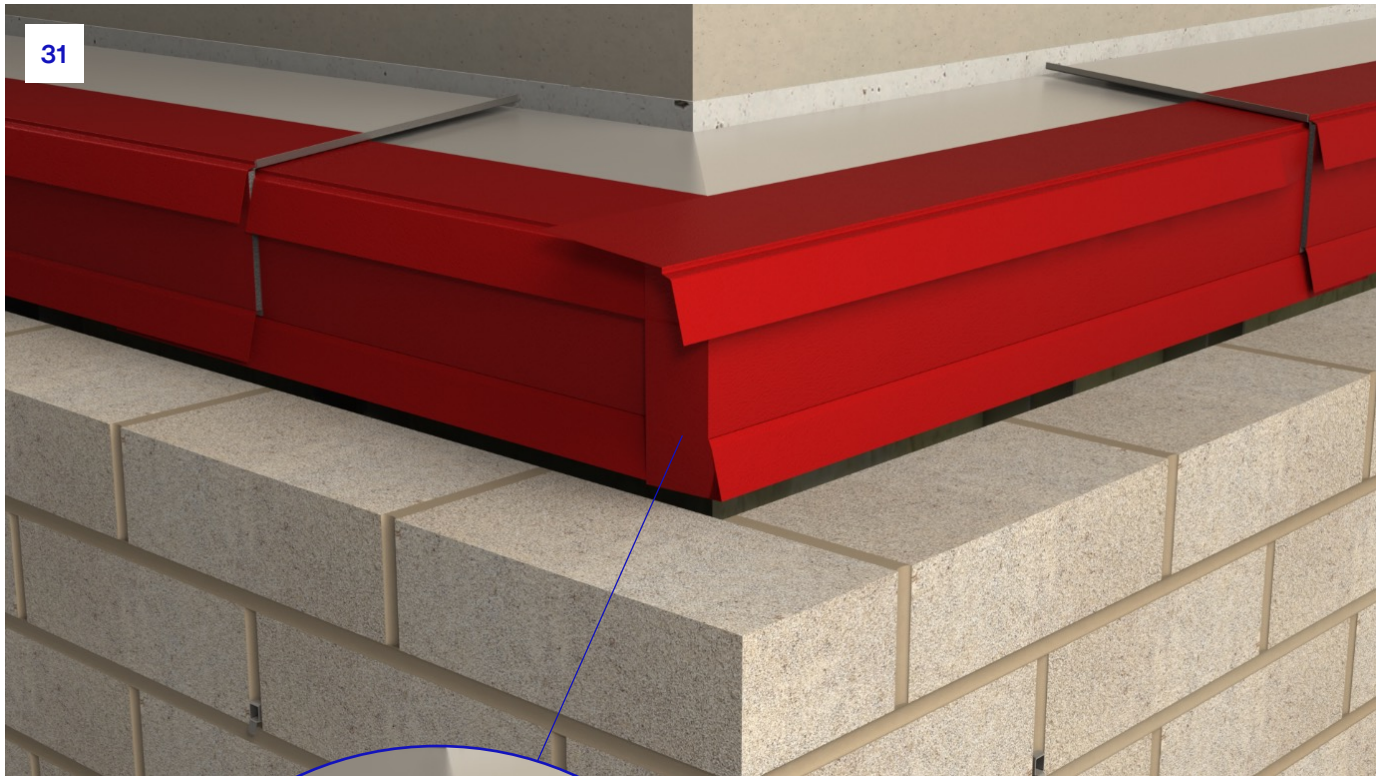

**31.** Brickwork should be built up to the level of the barrier and the wing on the front intumescent strip pushed inboard of the brickwork line. The wings should under no circumstance be built into the brickwork itself. More detail can be seen in the image below.

# Intex™ 4-in-1 Masonry Support System

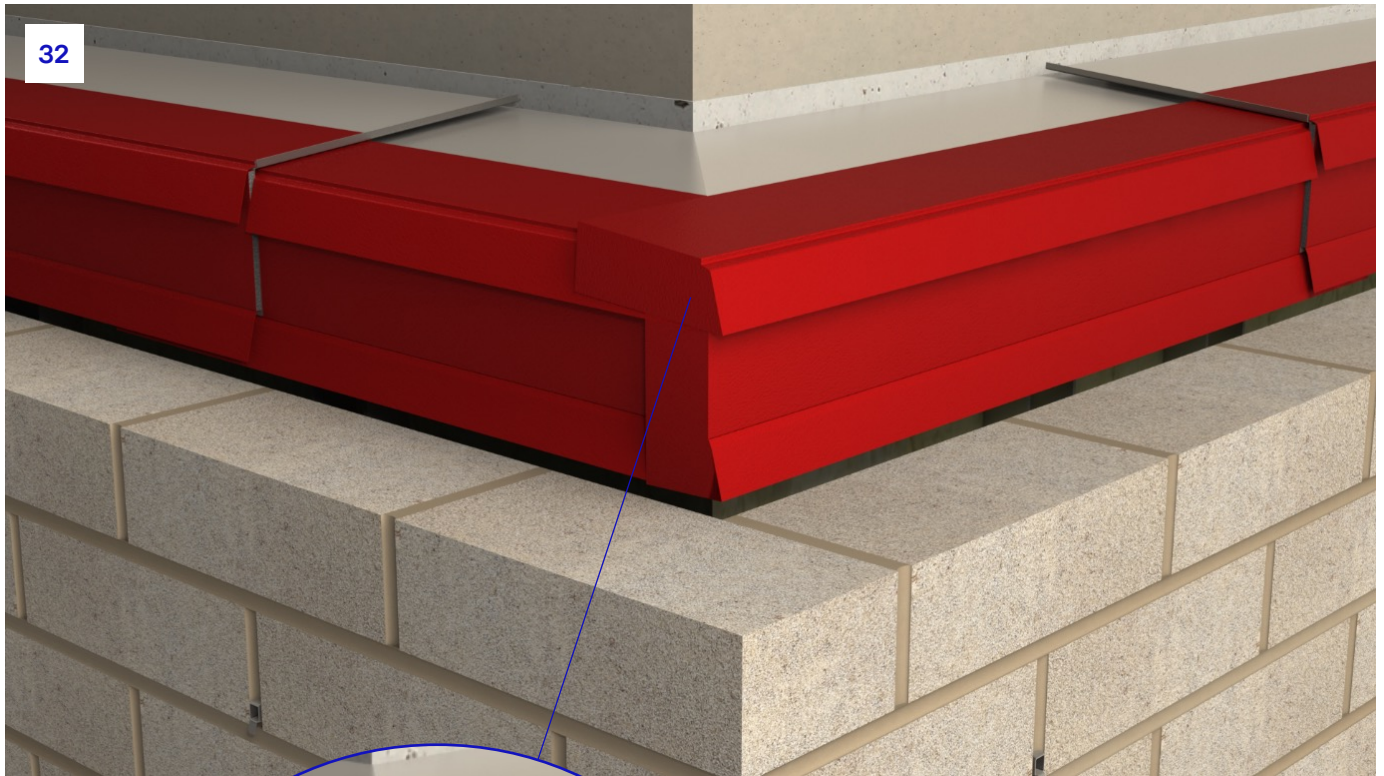

**32.** The same process should also be followed for the top intumescent strip, again ensuring that the wing is not built into the brickwork itself and is free to move under pressure in the case of a fire. More detail can be seen in the below image.



# Intex™ 4-in-1 Masonry Support System

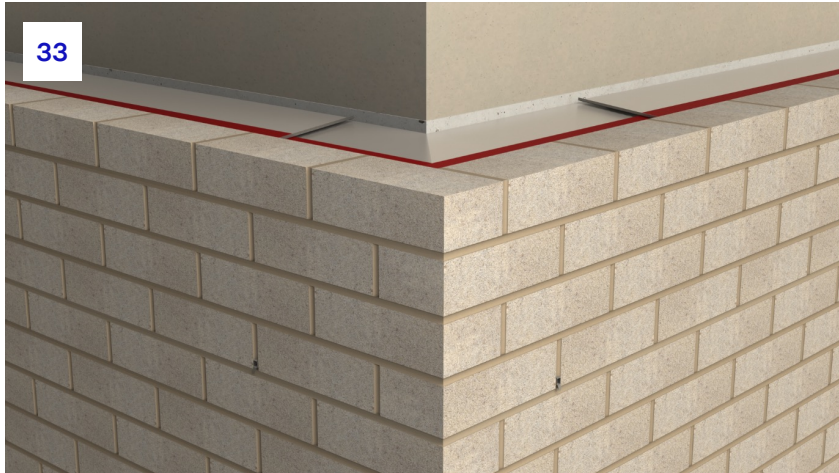

**33.** Brickwork can then continue up the façade ensuring that brick ties are installed as per the design team instructions.

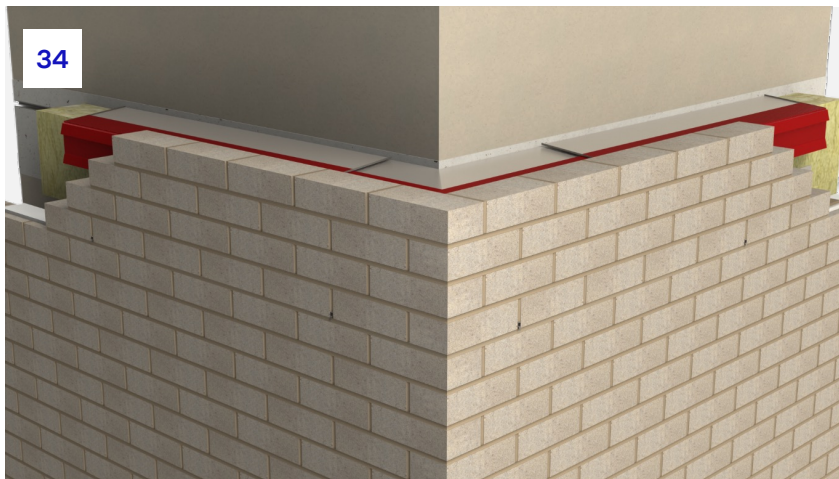

**34.** Please follow industry guidance around maximum build heights per day.

# Intex™ 4-in-1 Masonry Support System

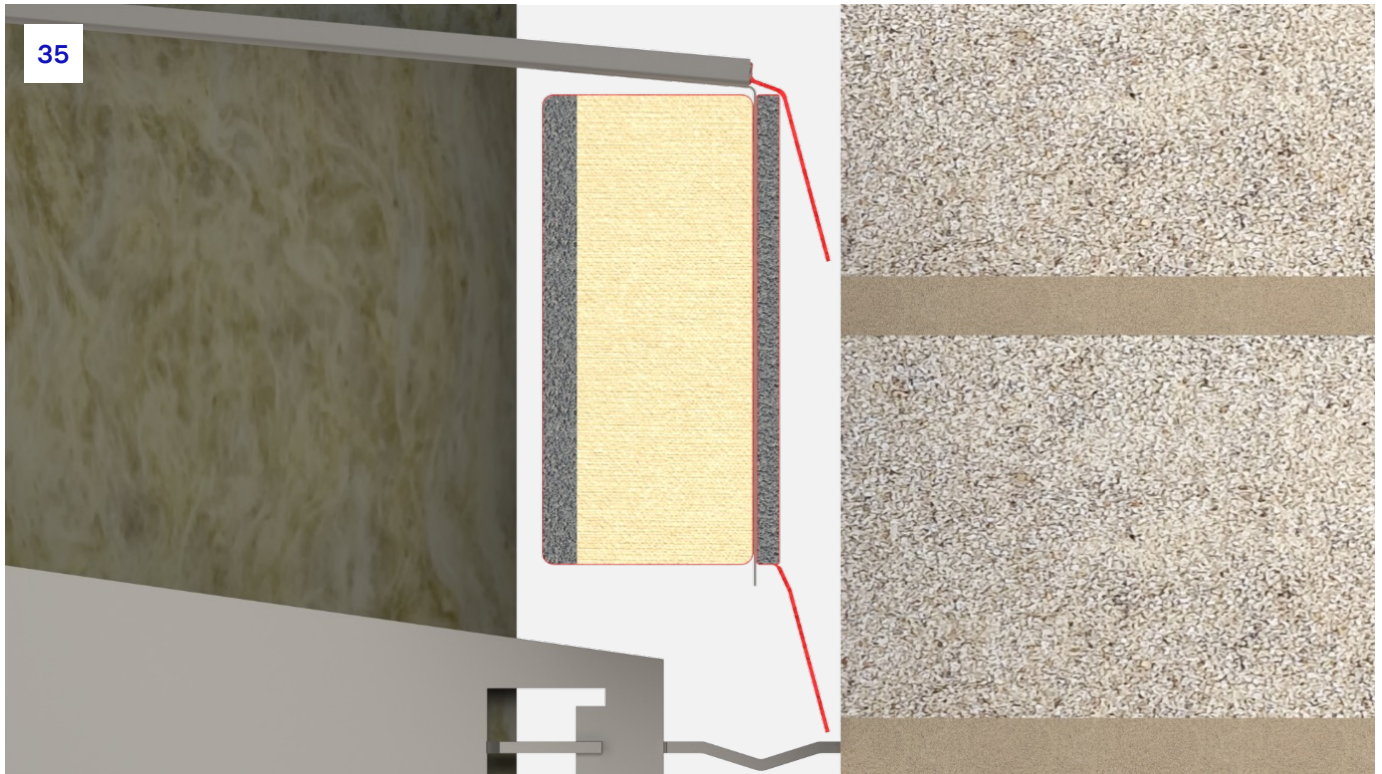

**35.** As brickwork continues up the façade, it is imperative that the barrier wings are left free within the cavity space. Under heat and fire, the wing expands into the brickwork to assist with intumescent expansion.



Built on tradition. Driven by innovation.

Get in touch to learn more  
about how Intex™ can help  
you deliver your next project.

0113 391 8200  
[info@acsstainless.co.uk](mailto:info@acsstainless.co.uk)  
[acsstainless.co.uk](http://acsstainless.co.uk)

✕ [ACSStainlessSteelFixings](#)  
🏢 [ACS Stainless Steel Fixings Ltd](#)